



RULES FOR EVENTING

23rd Edition effective 1st January 2009

The last updates applicable from January 1st, 2010, are shown **in red**, text which has been deleted is indicated by a ~~strikethrough~~

Latest updates on FEI website: 22 December 2009

Printed in Switzerland

Copyright © 2009 Fédération Equestre Internationale

Reproduction strictly reserved

Fédération Equestre Internationale
Avenue Rumine 37
1005 Lausanne
Switzerland

t + 41 21 310 47 47
f +41 21 310 47 60
e info@fei.org
www.fei.org

2010 RULES FOR EVENTING

TABLE OF CONTENT	PAGE
CODE OF CONDUCT FOR THE WELFARE OF THE HORSE	9
PREAMBLE	9
Chapter I General	10
Article 500 INTRODUCTION	10
1. General	10
2. Responsibility	10
3. National Safety Officers	10
Article 501 DEFINITION	10
1. CCI - Three Day Event	10
2. CIC	10
3. Validity	11
Article 502 CLASSIFICATION	11
1. Classification in the Three Tests	11
2. Individual Final Classification	11
3. Team Final Classification	11
4. Disqualification or Elimination	12
5. Disqualification due to positive Doping test an athlete or horse	12
Article 503 CATEGORIES & LEVELS OF EVENTS	12
1. International Events	12
2. Categories	12
3. Events limited to Seniors	13
4. The levels of Events	13
5. The proposed dates	13
Article 504 INDIVIDUAL & TEAM COMPETITION	13
1. CCIs	13
2. CICs	13
3. CCIOs/CICOs, Games & Championships	13
4. Teams	13
Article 505 PARTICIPATION OF ATHLETES & HORSES	14
1. Age of Athletes	14
2. Age of Horses	14
3. Nationality of Athlete & Owner	14
4. Number of Horses per Athlete	15
5. Young Horse Classes	15
6. Ponies	15
7. Games, Championships & Cups	15
8. Restriction on Horses	15
Article 506 QUALIFICATION MINIMUM ELIGIBILITY REQUIREMENTS FOR ATHLETES & HORSES	16
1. Principles	16
2. Definitions	16
3. Certification of Qualification Minimum Eligibility Requirements for Events	16
4. Qualifying Period and Deadline	17

2010 RULES FOR EVENTING

5.	Required Minimum Qualifying Results (QRs) Eligibility Requirements (MER) for CIO, CCI & CIC	17
6.	Exemptions CCIO/CCI/CIC	17
7.	Championships	18
8.	Permanent Athlete Qualification for CCIs and CICs	18
9.	Establishment of Qualification Minimum Eligibility Requirements	18
10.	Extension of Establishment (maintaining qualification Minimum Eligibility Requirements)	19
11.	Disqualification	19
Article 507	INVITATIONS	19
1.	Invitations	19
2.	CCIs & CICs	19
3.	CCIOs	19
4.	Championships	20
5.	Games, Championships & Cups	20
Article 508	EXPENSES	20
1.	CCIs/CCIOs/CICs	20
2.	Championships	20
3.	Games & Cups	21
Article 509	SCHEDULE and RESULTS	21
Article 510	ENTRIES	21
1.	CCIOs/CCIs/CICs	21
2.	Championships	21
3.	Declaration of Starters	22
4.	Substitutions	23
Article 511	REGISTRATION OF ATHLETES AND HORSES	23
1.	Athletes	23
2.	Horses	23
Article 512	DRAW	23
1.	Events with Individual Classification only	23
2.	Events with Team and Individual Classifications	23
3.	Approval of Method of Draw	25
Article 513	STARTING ORDER	25
1.	At a Three Day Event	25
2.	The starting order in the Jumping Test	25
3.	At a CIC	25
Article 514	TIMETABLE	25
1.	Dressage Test	25
2.	Cross-Country Test	25
3.	Jumping Test	25
4.	CICs	25
Chapter II	General Rules	27
Article 515	EXERCISING & WARMING-UP	27
1.	Identification Number	27
2.	Restrictions on Schooling Horses	27
3.	Exercise Areas	27
4.	Practice Dressage Arena	27

2010 RULES FOR EVENTING

5. Practice Obstacles	27
6. Stewards	28
Article 516 ACCESS TO COURSES & ARENAS	28
1. Dressage Arena	28
2. Cross-Country Courses	28
3. Jumping Course	28
Article 517 INTERRUPTIONS & MODIFICATIONS	29
1. Interruptions	29
2. Modifications	29
Article 518 INSPECTION & EXAMINATION OF HORSES	29
1. Championships & CCIOs & CCIs	29
2. CICs—exceptional-alternative Horse Inspection procedures at all CIC competitions	31
Article 519 HORSE & ATHLETE WELFARE	31
1. Eventing Risk Management Vision statement	31
2. Control of Medication of Horses	32
3. Athlete Fitness & Medical card	32
4. Examination after a fall - Medical Fitness	32
5. Control of Medication of Horses	33
6. Elimination of Athlete after Dressage	33
7. Dangerous Riding	33
Article 520 ABUSE OF HORSES AND DANGEROUS RIDING	34
1. Any act or series of actions	34
2. Whips	34
3. Warning “Yellow” Cards	35
Article 521 DRESS	35
1. Protective Headgear	35
2. Whips	35
3. Spurs	36
4. Boots	36
5. Dressage Test	36
6. Cross-Country Test	37
7. Jumping Test	37
8. Advertising and Publicity on Athletes & horses	37
9. Inspection of Dress	37
Article 522 SADDLERY	38
1. Exercise Areas	38
2. Dressage Test	38
3. Cross-Country Test & Jumping Test	38
4. Inspection of Saddlery	39
Chapter III Dressage Test	40
Article 523 RULES FOR DRESSAGE EVENTS	40
Article 524 THE NATURE OF DRESSAGE TEST	40
2. Number of Tests to be judged by day	40
Article 525 JUDGES POSITION	40
Article 526 SCORING	41

2010 RULES FOR EVENTING

1. Marking	41
2. Calculation of Scores	41
Chapter IV Cross-Country Test	42
Article 527 OBJECT	42
1. Cross Country	42
Article 528 CROSS COUNTRY	42
1. CCI Event	42
2. CIC Event	42
Article 529 RULES GOVERNING THE CROSS COUNTRY TEST	42
1. Starting	42
2. Time	43
3. Error of Course	43
4. Pace & Dismounting	43
5. Overtaking	43
6. Athletes in Difficulty	44
7. Stopping Athletes	44
8. Unauthorised Assistance	44
9. After Elimination	45
10. Closed circuit Television	45
Article 530 COURSES	45
1. Marking	45
2. Distances & Speeds	46
3. Finishing Lines	46
4. Course Plans	46
Article 531 OBSTACLES	46
1. Definition	46
2. Obstacles with Elements or Options	46
3. Type of Obstacles	47
4. Number of Jumping Efforts	47
5. Dimensions	47
6. Measurement	48
Article 532 SCORING	48
1. Faults at Obstacles	48
2. Time Faults	49
3. Additional Reasons for Elimination	49
Article 533 DEFINITIONS OF FAULTS	50
1. Refusal	50
2. Run-out	50
3. Circle	50
4. Fall	51
5. Obstacle composed of Several Elements	51
6. Instruction to Officials	51
Chapter V Jumping Test	52
Article 534 RULES FOR JUMPING EVENTS	52
Article 535 OBJECT & GENERAL DESCRIPTION	52
1. This test	52

2010 RULES FOR EVENTING

2. The nature of the course,	52
Article 536 SIZE OF ARENA	52
Article 537 COURSE - OBSTACLES	52
1. Distance & Speed	52
2. General	52
3. Dimensions	53
4. Type of Obstacles	53
Article 538 SCORING	53
1. Faults on the Course	53
2. Time Faults	53
Article 539 TIME CORRECTIONS	53
1. Knock-down with Disobedience	53
Chapter VI Games, Championships & Cups	55
Article 540 OLYMPIC GAMES	55
Article 541 WORLD INDIVIDUAL & TEAM CHAMPIONSHIPS	55
1. Organisation	55
2. Invitations	55
3. Qualifications	55
4. Participation	55
5. Expenses & Privileges	56
Article 542 WORLD CUPS FOR INDIVIDUALS	56
Article 543 CONTINENTAL GAMES	56
Article 544 CONTINENTAL INDIVIDUAL & TEAM CHAMPIONSHIPS	56
1. Organisation	56
2. Invitations	57
3. Qualifications	57
4. Participation restrictions - Young Riders and Junior Championships	57
5. Number of horses' per Athlete at a Championship	57
6. Expenses & Privileges	57
7. Young Rider & Junior Championships – Responsibility	57
8. Young Rider & Junior Championships – Medals & Prizes	58
Article 545 CONTINENTAL CUPS FOR INDIVIDUALS	58
Article 546 REGIONAL GAMES	58
Article 547 REGIONAL INDIVIDUAL & TEAM CHAMPIONSHIPS	58
Chapter VII Officials at International Events	59
Article 548 JURISDICTION OF OFFICIALS	59
Article 549 DUTIES OF OFFICIALS	59
1. Ground Jury	59
2. Technical Delegate	60
3. Course Designer	61
4. Veterinary Commission	61
5. Appeal Committee	62
6. Stewards	62
7. Conflict of Interest	62
Article 550 APPOINTMENT OF OFFICIALS	63

2010 RULES FOR EVENTING

1. Games, Championships, Cup Finals	63
2. Three Day Events (CCIs)	64
3. CIC Events	65
4. Veterinarians	66
5. Appeal Committee	66
6. Stewards	66
7. Appointment Restrictions	66
8. Assistant Technical Delegate	67
9. Number of TDs per event	67
10. Course Designer	67
Article 551 JUDGES	67
1. Categories of Judges	67
2. Qualifications of Judges	67
3. Promotion of Judges	68
4. Fulfilment of Requirements	69
Article 552 TECHNICAL DELEGATES	69
1. Categories of Technical Delegates	69
2. Qualifications of Technical Delegates	69
3. Promotion of Technical Delegates	70
4. Fulfilment of Requirements	70
Article 553 COURSE DESIGNERS - EVENTING	70
1. Categories of Course Designers	70
2. Qualifications of Course Designers	70
3. Promotion of Course Designers	71
4. Fulfilment of Requirements	71
ANNEX 1a	72
Permitted Bits for the Dressage Test	72
Drawings permitted bits	73
Drawings - permitted snaffles	75
ANNEX 1b	76
Permitted Nosebands for the Dressage Test	76
ANNEX 2	77
Dressage Tests For Eventing	77
ANNEX 3a	78
Table of CCI Cross-Country Obstacle heights & Spreads/ Table of Speeds, Times, Distances & Maximum Jumping Efforts	78
ANNEX 3b	78
CCI / CIC Table of Speeds, times, distances & maximum Jumping Efforts	78
ANNEX 4	80
Table of Jumping Obstacle Heights & Spreads / Distances, Speeds & Maximum Jumping Efforts	80
ANNEX 5	81
Diagram of Cross Country Obstacles & Faults	81

2010 RULES FOR EVENTING

ANNEX 6	FEI Badges for Honour	85
ANNEX 7		86
	Recommendations for Medical Services at FEI Competitions	86
ANNEX 8		88
	Organising Requirements for Eventing 4 Star Level Events	88
ANNEX 9		89
	Directives For One & Two Star CCI/CIC with Several Sections for the Same level in Regard to Ground Juries	89
ANNEX 10		90
	Consultation with Athletes	90
	1. Appointment of Athlete Representative	90
	2. Chairman of Ad Hoc Committee (AHC)	90
	3. 1st meeting of Athletes called by the Athlete Representative – 1st HI	90
	4. 2nd meeting of Athletes called by the Athlete Representative after 1st day Dressage	90
	5. Meeting Minutes	90
	6. Additional Athlete Representative	90
	7. Final Athletes Meeting of the Athletes before the Cross Country	91
	8. Athletes Briefing	91
	9. Ad-Hoc Committee	91
	10. Events with only 1 day Dressage	91
ANNEX 11		93
	Young Rider/Junior Championships - SCHEDULE Information	93
ANNEX 12		94
	Rules for Eventing Pony Riders	94
	Administrative Rules	94
	Technical Rules	95
	Article P9 – Jumping Test	96
	Article P10 - Officials	97
	Article P11 - Continental Championships	98
NEW ANNEX 13		101
	1. FEI Stable Security	101
	2. Reduced Stable Security	101

CODE OF CONDUCT FOR THE WELFARE OF THE HORSE

The Fédération Equestre Internationale (FEI) expects all those involved in international equestrian sport to adhere to the FEI's Code of Conduct and to acknowledge and accept that at all times the welfare of the horse must be paramount and must never be subordinated to competitive or commercial influences.

At all stages during the preparation and training of competition horses, welfare must take precedence over all other demands. This includes good horse management, training methods, farriery and tack, and transportation.

Horses and athletes must be fit, competent and in good health before they are allowed to compete. This encompasses medication use, surgical procedures that threaten welfare or safety, pregnancy in mares and the misuse of aids.

Events must not prejudice horse welfare. This involves paying careful attention to the competition areas, ground surfaces, weather conditions, stabling, site safety and fitness of the horse for onward travel after the event.

Every effort must be made to ensure that horses receive proper attention after they have competed and that they are treated humanely when their competition careers are over. This covers proper veterinary care, competition injuries, euthanasia and retirement.

The FEI urges all involved with the sport to attain the highest levels of education in their areas of expertise.

PREAMBLE

The present "Rules for Eventing" are effective from 1st January 2010. As of this date, all other texts of the Rules or amendments to them dated prior to this date are superseded.

Although this booklet sets out the detailed Rules of the FEI governing International Eventing, it must be read in conjunction with the "Statutes", "General Regulations", "Veterinary Regulations" and the "Memorandum for Eventing".

Every eventuality cannot be provided for in these Rules. In any unforeseen or exceptional circumstances, it is the duty of the Ground Jury in consultation with the Technical Delegate to make a decision in a sporting spirit and to approach as nearly as possible the intention of these Rules and the "General Regulations".

Chapter I General

Article 500 INTRODUCTION

1. **General**

Eventing constitutes the most complete combined competition, demanding of the athlete considerable experience in all branches of equitation and a precise knowledge of his horse's ability, and of the horse a degree of general competence, resulting from intelligent and ~~rational~~ **progressive** training.

2. **Responsibility**

An athlete is ultimately responsible for knowing these rules and complying with them. The appointment of a steward or official, whether or not provided for in these rules, does not absolve the athlete from such responsibility.

3. **National Safety Officers**

All National Federations organizing International Eventing Events must appoint an active national safety officer (NSO), to liaise with the FEI with regards to all matters directly relating to Eventing Risk Management.

Article 501 DEFINITION

1. **CCI - Three Day Event**

A Three Day Event comprises three distinct tests, taking place on separate days, during which an athlete rides the same horse throughout, namely:

1.1 DRESSAGE TEST - A Dressage Test spread over one or more consecutive days, depending on the number of athletes, directly followed on the next day by:

1.2 CROSS-COUNTRY TEST - A Cross-Country Obstacles Test, the Cross-Country will be directly followed on the next day by:

1.3 SHOW JUMPING TEST -

Note: For events organizing International CCI with Phase A, B and C, 2008 Rules for Eventing articles referring to Steeple-chase & roads and tracks will apply. Penalties received on phases A,B & C will not be included in FEI results or count for Qualification results.

2. **CIC**

CIC Events comprise the same three tests. The event may take place over 1, 2 or even 3 days. The Dressage Test always takes place first. Either the cross country or the show jumping may form the last test.

2010 RULES FOR EVENTING

3. Validity

These Rules have been adopted to apply principally to Three Day Events. Unless clearly not applicable, they apply equally to CIC Events.

Article 502 CLASSIFICATION

1. Classification in the Three Tests

1.1 IN THE DRESSAGE TEST, each athlete's good marks awarded by the judges are converted into penalty points. They are recorded for inclusion in the final classification and published.

1.2 IN THE CROSS-COUNTRY TEST, each athlete's penalties for faults at obstacles are added to the penalties that he may have incurred for excess time on Cross country. They are recorded for inclusion in the final classification and published.

1.3 IN THE JUMPING TEST, each athlete's penalties for faults at obstacles are added to the penalties that he may have incurred for excess time. They are recorded for inclusion in the final classification and published.

2. Individual Final Classification

2.1 THE WINNING INDIVIDUAL is the athlete with the lowest total of penalty points, after adding together, for each athlete, the penalty points incurred.

2.2 In any International Event, in the event of **EQUALITY BETWEEN TWO OR MORE ATHLETES**, the classification is decided by:

1. The best cross-country obstacle score including faults at obstacles and time penalties.
2. If there is still equality, the classification is decided in favour of the athlete whose cross-country time was closest to the optimum time.
3. If there is still equality, the athlete with the best Jumping score (time & obstacles).
4. If there is still equality, the athlete with the best time (fastest) in the Jumping Test.
5. If there is still equality, the classification will be decided in favour of the athlete with the best percentage score in the Dressage Test.
6. If there is still equality the tie will remain in the Final Classification.

3. Team Final Classification

3.1 THE WINNING TEAM is that with the lowest total of penalty points, after adding together the final scores of the three highest placed athletes in the team. For the purposes of Team Classification only, an athlete who fails for any reason to complete the entire competition will be awarded 1000 penalty points.

3.2 IN THE EVENT OF EQUALITY between any two or more teams, the classification will be decided by the best combined highest three placings – e.g. a team with athletes ranked individually 2nd, 8th and 12th, team total

2010 RULES FOR EVENTING

22, will beat one with athletes ranked 1st, 7th and 15th, team total 23. Should these figures be equal, a tie shall be declared.

4. Disqualification or Elimination

Disqualification or elimination from one of the tests entails disqualification or elimination from the final classification.

5. Disqualification due to positive Doping test an athlete or horse

5.1 OFFICIAL TEAM COMPETITION - Should an athlete and/or horse be disqualified for positive doping test, the athlete's result will be annulled. The teams result will be recalculated not taking into account the results achieved by the disqualified athletes/horse.

1. If by removing the disqualified member from the team, the number of the team members is still within the minimum required number of three athletes/horses per team; the team will be considered eligible and be classified accordingly.

2. If by removing the disqualified member from the team results, the number of the team members falls under the minimum required number (less than three athlete/horses per team), the team shall be disqualified. The classification of the other teams will be amended accordingly and prizes / (medals if applicable) redistributed.

5.2. INDIVIDUAL CLASSIFICATION - If an athlete and/or horse is disqualified in the Individual event due to a positive doping test, the athlete's results will be annulled and the next placed athlete will move up accordingly and prizes (medals if applicable) redistributed.

All ties will be broken according to paragraph 2 above.

Article 503 CATEGORIES & LEVELS OF EVENTS

1. International Events are denoted by their category and their level, for example: a CCI2* is an International Three Day Event at the Two Star level.

2. Categories indicate the type of competition and the extent of foreign participation in an Event. The four categories of events are:

2.1 NATIONAL EVENTS (CCN/CNC) - normally limited to national athletes, a CCN may be open to a maximum of six athletes not resident in the host country from not more than two foreign nations.

2.2 INTERNATIONAL EVENTS (CCI/CIC) - open to athletes from the host nation and to athletes from an unlimited number of foreign nations.

2.3 OFFICIAL INTERNATIONAL EVENTS (CCIO/CICO) - open to athletes from an unlimited number of nations, with an official team competition.

2.4 CHAMPIONSHIPS (CH) - with an official team competition, (unless specifically agreed by the Secretary General and the Chairman of the Eventing Committee) open to athletes from an unlimited number of nations, but may be confined to a continental or regional area.

2010 RULES FOR EVENTING

3. Events limited to Seniors are indicated by the letters noted above, for example: CCI3*. Events limited to Young Riders are indicated by the addition of the letter "Y", for example: CCIOY2*. Events limited to Juniors are indicated by the addition of the letter "J", for example: CCIJ1*.

4. The levels of Events are indicated by stars, ranging from One Star to Four Star. The Four Star Three Day events are those that require the highest level of training and experience from both horse and athlete. The levels of CIC Events range from One Star to Three Star.

CICs for Juniors may be held at the One or Two Star level.

CCIs may be offered at any level. CCIOs may be offered from One to Three Star level. The location, dates and levels of CCIOs must be approved by the Secretary General and the Chairman of the Eventing Committee. Each NF may only organise one CCIO in any calendar year. For the levels of competition at Games, Championships and Cups, see Chapter VI. NFs are encouraged to use stars to denote levels of CNS.

5. The proposed dates for a CIC must not, in the opinion of the FEI, damage CCIs, CCIOs, Games or Championships.

Article 504 INDIVIDUAL & TEAM COMPETITION

1. CCIs

There may be a team competition, an individual competition or both. When there are both, each member of a team will automatically be considered also as an individual athlete.

2. CICs

Unless otherwise agreed by the FEI, there must only be an individual competition.

3. CCIOs/CICOs, Games & Championships

There must always be a team and an individual competition, unless specifically agreed by the Secretary General and the Chairman of the Eventing Committee.

4. Teams

Teams will always be composed of athletes from the same nation. Teams will consist of either three or four athletes. Where there are four, the three best will be counted for the final classification. At CCIs, the number of teams from each nation is at the discretion of the Organising Committee. At CCIO/CICOs, Games and Championships each nation may enter only one team, except where additional regional teams are permitted by these Rules.

2010 RULES FOR EVENTING

Article 505 PARTICIPATION OF ATHLETES & HORSES

1. Age of Athletes

1.1 JUNIORS - An Athlete may compete as a Junior from the beginning of the calendar year in which he reaches the age of 14 (fourteen) until the end of the calendar year in which he reaches the age of 18 (eighteen).

1.2 YOUNG RIDERS - An Athlete may compete as a Young Rider from the beginning of the calendar year in which he reaches the age of 16 (sixteen) until the end of the calendar year in which he reaches the age of 21 (twenty-one).

1.3 SENIORS - An athlete may compete as a Senior from the beginning of the calendar year in which he reaches the age of 18 (eighteen). With the express permission of his NF, an athlete may compete as a Senior in a Two Star competition from the beginning of the calendar year in which he reaches the age of 16 (sixteen). With the express permission of his NF, an athlete may compete as a Senior in a One Star competition from the beginning of the calendar year in which he reaches the age of 14 (fourteen).

1.4 CHAMPIONSHIP CATEGORY RESTRICTIONS - An athlete may only compete at one FEI Junior, Young Rider or Senior Championship in the same year.

2. Age of Horses

2.1 ONE / TWO STAR LEVEL CCIs AND CHAMPIONSHIPS - A horse may compete in an International Three Day Event or CCIO or Championships of a One and Two Star level from the beginning of the calendar year in which he reaches the age of six.

2.2 THREE/ FOUR STAR LEVEL EVENTS - A horse may compete in an International Event or CCIO of a Three and Four Star level from the beginning of the calendar year in which he reaches the age of seven (7).

2.3 THREE / FOUR STAR LEVEL CHAMPIONSHIPS - A horse may compete in a championship of a Three Star level from the beginning of the calendar year in which he reaches the age of seven (7), and in a championship of a Four star level from the beginning of the calendar year in which he reaches the age of eight (8).

2.4 ONE / TWO / THREE STAR LEVEL CICS - A horse may compete in a CIC Event at the One and Two Star level from the beginning of the calendar year in which he reaches the age of five; and at the Three Star level from the beginning of the calendar year in which he reaches the age of six.

3. Nationality of Athlete & Owner

Athletes may take part in all competitions (Championships, CCIOs, and other International Events, including Juniors, Young Riders or Seniors) except Olympic Games with horses belonging to owners of a different nationality (see "General Regulations", Art. 141.5).

2010 RULES FOR EVENTING

4. Number of Horses per Athlete

4.1 IN A CHAMPIONSHIP, an athlete may only ride one horse.

4.2 AT A CCIO or where there is a team competition at a CCI, an athlete may ride only one horse as a member of a team and may ride in only one team.

4.3 THERE IS NO LIMITATION to the number of horses an athlete may ride in an individual Three Day or CIC Event, with the following exceptions:

1. THE ORGANISING COMMITTEE may impose a limitation, in its absolute discretion, whether for time-tabling or any other reason. Such a limitation must be published in the Schedule.

2. WHERE ANY EVENT has more entries than it can accommodate, no athlete may ride more than two horses (or one horse if so decided by the OC).

3. NO ATHLETE MAY RIDE MORE than 4 horses in any one day of cross country at a Three Day Event.

Where an athlete has a horse in a team competition, he must always ride that horse before a horse in the individual competition.

5. Young Horse Classes

Classes may be organised that are confined to Young Horses (six & seven year old) and/or an additional classification for Young Horses within a competition may be organised. Such classes or classifications may only take place at CICs or at CCIs at the One and Two Star level and will be organised strictly in accordance with the rules for that level. Qualification for Young Horse classes/Championships to be established separately by the Eventing Committee on an annual basis.

6. Ponies

Senior, Young Rider and Junior Three Day and CIC Events are open equally to horses and ponies, provided they and their athletes meet all the relevant qualifications.

7. Games, Championships & Cups

For the special requirements to participate in Games, Championships or Cups, see Chapter VI.

8. Restriction on Horses

~~At any International Event, no~~ A horse that has obtained a Qualifying Result at a Four Star level CCI in the current or preceding year may **not** be entered for a One Star ~~or a two star~~, unless the athlete has not completed a Three Star Event or a Four Star Three Day Event.

Junior Championships are open to all horses except those which have competed in a Four Star CCI, in an Eventing championship for Seniors or in Eventing at the Olympic Games during the preceding or current year.

2010 RULES FOR EVENTING

Article 506 ~~QUALIFICATION~~ **MINIMUM ELIGIBILITY REQUIREMENTS FOR ATHLETES & HORSES**

1. Principles

In order to compete at an international event, an athlete and horse must have obtained a ~~Qualifying Result (QR)~~ **Minimum Eligibility Requirement (MER)** at a number of events at a lower level.

The requirements are laid out below. With the approval of the FEI and their own NF, OCs may impose additional ~~qualifications~~ **Minimum Eligibility Requirements** for horses and/or athletes, which must be published in the Schedule.

NFs are encouraged to set stronger ~~qualifications~~ **Minimum Eligibility** standards than FEI requirements for horses/athletes at all levels of events.

2. Definitions

2.1 TYPE & LEVEL OF QUALIFICATION MINIMUM ELIGIBILITY REQUIREMENTS - Type and levels of Events are detailed in Article 503

2.2 ~~QUALIFYING RESULT (QR)~~ MINIMUM ELIGIBILITY REQUIREMENTS (MER)

1. A ~~qualifying result (QR)~~ **minimum eligibility requirement (MER)** is achieved by completing a competition within minimum parameters of all round performance. As follows:

2. Dressage Test: not more than 75 penalty points;
3. Cross-Country Test,

From 2009 onwards, the results at International events need to include, where applicable, a clear round (0 penalties) at obstacles for CIC events and maximum 20 penalties at a CCI event.

4. Not more than 90 seconds exceeding the optimum time in the Cross. At 4* events, the maximum time by which the optimum time may be exceeded is 120 seconds; and
5. Jumping Test: not more than 16 penalties at obstacles.

3. Certification of Qualification **Minimum Eligibility Requirements for Events**

3.1 ALL NF'S, including the host nation, are responsible to certify that athletes and horses entered by them in international events are correctly qualified in accordance with all the requirements of the Rules.

3.2 ALL QUALIFYING EVENTS must be identified, and any national events must be certified as of at least the equivalent standard of difficulty as the relevant international star level of competition. The FEI can request results of National events at any time.

3.3 THE TECHNICAL DELEGATE OR HIS NOMINEE shall check that all horses and athletes starting at all International events are properly certified as

2010 RULES FOR EVENTING

qualified having obtained **Minimum Eligibility Requirements** by their NF or duly exempted in accordance with this article.

4. Qualifying Period and Deadline

4.1 QRs MER FOR CIOs, CCI and CICs must be obtained in the calendar year in question or the 2 preceding calendar years.

4.2 A QR MER AT A CCI must be obtained at least 24 days before the Cross Country test of the event for which it is needed; a QR MER at a CIC must be obtained at least 10 days before the event for which it is needed.

4.3 QUALIFICATIONS MINIMUM ELIGIBILITY REQUIREMENTS may be achieved as a combination or separately by athlete and horse.

4.4 WHERE A QR MER AT A CIC is specified, one QR MER at a CCI of the same level is equally acceptable.

5. Required Minimum Qualifying Results (QRs) Eligibility Requirements (MER) for CIO, CCI & CIC

	CCI / CCIO	CIC / CICO
1*	Horses and athletes must be certified as competent by their NF.	Horses and athletes must be certified as competent by their NF.
2*	Minimum 2 QRs (MER) required: 1x CCI1* or 1x CIC2* plus 1x CIC2* or 2x CNC2*	Minimum 1 QR (MER) required: 1x CIC1* or 1x CNC2*
3*	Minimum 3 QRs (MER) required: 1x CCI2* plus 1x CIC3* plus 1x CIC3* or CNC3*	Minimum 2 QRs (MER) required: 1x CIC2* plus 2x CIC2* or 1x CNC3*
4*	Minimum 3 QRs (MER) required: 1x CCI3* plus 1x CIC3* plus 1x CIC3* or 2x CNC3*	not applicable

In order to move up a level, one CICs results of the international qualifying results **Minimum Eligibility Requirements** must be clear (0 penalties) on the Cross Country obstacles (no XC obstacles penalties).

6. Exemptions CCIO/CCI/CIC

Under exceptional circumstances, the FEI may before the event, with the agreement of the Organising Committee of a CCIO/CCI/CIC and the NF of the host country, waive the qualifying standard for a horse, but only at the specific written request of the athlete's NF. Such a request must be accompanied by the reasons for the request and a detailed summary of both the horse and athlete's performance record, including all the horse's competitions at national and international CIC Events and Three Day Events during the current and previous year. Such exemptions will be considered

2010 RULES FOR EVENTING

only for specific selection purposes for Championships/Games in the **Minimum Eligibility Requirements** year.

7. Championships

7.1. CERTIFICATION - For Senior Continental and World Championships, NFs must send to the FEI a Certificate of Capability including a record of results, proving that their athlete and horse are ~~qualified according to the requirements~~ **have reached the Minimum Eligibility Requirements** by the date of the nominated entries or a date set by the FEI.

7.2. QUALIFYING PERIOD AND DEADLINE - ~~QRs~~ **MER** for Championships must be obtained in the calendar year in question or the preceding calendar year. At CIC1* Championships or Games, within 2 years of the competition, the athletes must have obtained at least 2 ~~qualifying results~~ **Minimum Eligibility Requirements**. The deadline for obtaining ~~QRs~~ **MER** is 4 weeks before the first Dressage day of the championship (corresponding to the nominated entries).

Qualifications must be achieved as a combination of athlete and horse.

7.3. REQUIRED ~~QUALIFYING RESULTS (QRs)~~ MINIMUM ELIGIBILITY REQUIREMENTS (MERS) FOR CHAMPIONSHIPS

CH-CIC 1*	1x CIC 1* + 1x CNC 1*
CH 1*	1x CCI 1*
CH 2*	1x CCI 2*
CH 3*	1x CCI 3*
CH 4* (WEG / OG)	1x CCI 4* OR 1x CCI 3* + 1x CIC 3*

7.4. EXEMPTIONS - No exemptions will be permitted for Championships.

8. Permanent Athlete Qualification for CCIs and CICs

When an athlete has, since January 1st 2002, achieved 5 ~~QRs~~ **MER at a 4 or 3 star** type/level of event, he can compete at that type/level (or lower) for life without further ~~QRs~~ **MER**.

Exception: Championships where ~~QRs~~ **MER** must be achieved as a combination see above.

NOTE: CCIs count towards Permanent Qualification for CICs of the same level, but CICs do not count towards Permanent Qualification for CCIs of the same level. The horse ridden by a 'permanently qualified' athlete must still fulfil the ~~qualifying~~ **Minimum Eligibility** standards.

9. ~~Establishment of Qualification~~ **Minimum Eligibility Requirements**

When the athlete obtains a ~~QR~~ **MER** at the higher level, then he and his horse are "established" (qualified to compete) at this higher level. This "establishment" lasts for the remainder of the year in which it was obtained and the 2 succeeding calendar years.

2010 RULES FOR EVENTING

NOTE: Re-qualification is required when the 2 year period has run out

10. Extension of Establishment (maintaining qualification Minimum Eligibility Requirements)

10.1 CCI

1. THE "ESTABLISHMENT" may be extended by obtaining QRs **MER** at other events of the same type and level within the 2 year period stated above, each extension remaining effective for the remainder of the calendar year and the 2 succeeding years. (see 9 above)

2. WHEN ESTABLISHMENT has expired for CCI, it can be renewed at any time with 2 clear rounds on **cross country obstacles and fulfilment of Minimum Eligibility Requirements parameters as defined above for Dressage and Jumping** (eg 2/3 year later) with 2 CIC/CNC of same level or higher during the 12 months before the event in question.

(To maintain the minimum requirement for 4star CCI, the establishment can be renewed with fulfilment of minimum requirements with 2 CIC/CNC at 3 star level.)

10.2 CIC

1. THE "ESTABLISHMENT" may be extended by obtaining QRs **MER** at other events of the same type and level within the 2 year period stated above, each extension remaining effective for the remainder of the calendar year and the 2 succeeding years. (see 9 above)

2. IF NO EXTENSION is obtained within the duration, the establishment at that level expires.

11. Disqualification

An athlete / horse combination having participated in an event without the appropriate ~~qualification~~ **Minimum Eligibility Requirement** will be disqualified from the specific event.

Article 507 INVITATIONS

1. Invitations

All invitations must be sent to NFs and not to an individual athlete.

2. CCIs & CICs

The NFs to be invited, and the number of athletes and horses per NF, are at the discretion of the Organising Committee but must be in accordance with Art. 504.2.

One groom per athlete must be invited.

3. CCIOs

Invitations must be in accordance with the "General Regulations". The OC may only restrict the number of nations to be invited with the agreement of the Secretary General and the Chairman of the Eventing Committee. At

2010 RULES FOR EVENTING

least five foreign nations must always be invited, each one being entitled to start at least six horses (or less if they wish). The number of athletes from the host nation is unlimited.

One groom per athlete and one official per nation must be invited.

4. Championships

Invitations must be sent to all eligible NFs. The number of athletes and horses will be in accordance with Art. 510.2.3.

One groom per athlete and one official per team must be invited.

5. Games, Championships & Cups

For invitations to these competitions, see Chapter VI.

Article 508 EXPENSES

1. CCI/CCI/Os/CICs

The scale of expenses to be offered is at the discretion of the Organising Committee. However, all athletes from the host nation, including foreign athletes resident in the host nation, must be offered the same scale of **reasonable** expenses. All other foreign athletes must be offered the same scale of expenses. However, this may be a different scale from that offered to national or resident foreign athletes.

2. Championships

2.1 SENIOR WORLD & CONTINENTAL CHAMPIONSHIPS - The Organising Committee of World and Continental Championships is responsible for meeting travelling and living expenses of the invited athletes, horses, grooms and additional officials as agreed to by the FEI and published in the Schedule. Travel shall be from the frontier of the host country, or the point of arrival in the host country, to the place of the event, including the cost of unloading from the aircraft or the ship, quarantine and customs duties. The same applies for the return journey.

Living expenses shall include accommodation, food and transportation, from the day before the First Horse Inspection until the day after the Jumping Test.

If an Entry fee for teams &/or Individuals is fixed by the OC, the OC is not required to meet the travelling or living expenses for the teams as referred to above.

2.2 YOUNG RIDERS & JUNIORS CONTINENTAL CHAMPIONSHIPS - NFs are responsible for the travelling expenses of their Chefs d'Equipe (also Team Veterinarian for Eventing), Athletes, grooms and horses to and from the location of these championships.

Organising Committees are required to provide:

1. Stabling and fodder for the horses are in principle, free of charge. A reasonable fee can be charged, it must be stated in the schedule;
2. Possibility for the grooms to stay in the immediate vicinity of the stables;

2010 RULES FOR EVENTING

3. One main meal, preferably in the evening for Athletes and Chefs d'Equipes (either on the show ground or otherwise);

4. If accommodation is not offered free, then suitable accommodation be arranged/ recommended and prices quoted in the schedule;

5. Agent and veterinary fees for entering and leaving the frontier of the organising country and/or the show grounds to be arranged and paid by the Organising Committee.

Only if cash prizes are awarded, reasonable entry fee or starting fee may be charged.

2.3 ALL PRIVILEGES are to be awarded from one day before the start of the championship until one day after.

3. Games & Cups

For the expenses and privileges of these competitions, see Chapter VI.

Article 509 SCHEDULE and RESULTS

For all Events with the exception of CICs/CCIs 2/1*, the schedule of the competition must be drafted in the form prescribed by the FEI. Two copies of the proposed schedule must be sent to the Secretary General for approval, at least sixteen weeks before the competition.

For CICs/CCIs 2/1* a copy of the schedule must be sent to the FEI at least 4 weeks before the competition.

Full result of the events must be forwarded to the FEI by the OC a maximum of 4 days after the event is finished (according to electronic format described by FEI).

Article 510 ENTRIES

1. CCIOs/CCIs/CICs

1.1 THE CONDITIONS for entries will be as published by the Organising Committee in the schedule of the competition. After the closing date for entries, there can be no change of horses, but a properly qualified athlete can be substituted up to the time announced for the declaration of starters.

1.2 ALL ENTRIES must be confirmed in writing by the Athletes NFs.

2. Championships

Entries must be made by the NFs in three phases as follows. In each case, the exact dates by which entries must be received will be published in the schedule of the competition. Entries received after the due date may be refused.

2.1 ENTRIES IN PRINCIPLE - At least eight weeks before. Each NF must inform the Organising Committee of its intention to send a team and/or individual athletes without giving the names of horses or athletes. The NF must specify how many horse/athlete combinations it wishes to take part in the event.

2.2 NOMINATED ENTRIES - At least four weeks before:

2010 RULES FOR EVENTING

1. EACH NF that has made an entry in principle, including the host NF, may enter up to three times the number of horses and athletes that are entitled to start. Within this limit, there is no restriction on the number of horses that may be entered for any athlete.

2. THE ATHLETE REGISTRATION number and the horse passport/registration number for all nominated athletes/horses must be included with the entries.

3. INDIVIDUALS IN ADDITION TO TEAMS - The following maximum number of individual athletes authorised to take part in addition to each team is fixed as follows: NFs will be advised by the Organising Committee at the closing of nominated entries.

1. Seven or more teams entered: two individuals per nation plus a further six individuals from the host nation.

2. Five or six teams entered: three individuals per nation plus a further eight individuals from the host nation.

3. Four or less teams entered: four individuals per nation plus a further ten individuals from the host nation.

If there are less than 35 entries in total, the number of individuals entered from each nation may be increased proportionally.

2.4 DEFINITE ENTRIES - They must reach the OC by letter or telecommunication by noon, at the latest four days before the First Horse Inspection of the event. After the definite entries have been sent in, substitutions of athletes and/or horses from the list of nominated entries may only be made with the express permission of the OC, but never less than two days preceding the beginning of the event.

1. EACH NF chooses from its list of nominated entries and definitely enters up to a maximum of its entitlement of starters with up to two additional horses. The two additional horses must be qualified with one of the athletes part of the maximum of entitlement of starters.

2. THESE are the athletes and horses that will travel to the competition.

3. Declaration of Starters

3.1 THE DECLARATION OF STARTERS will take place at a time to be announced by the Organising Committee. It will be after athletes have inspected the courses of the Cross-Country Test and after the First Horse Inspection.

3.2 IF there is only an individual classification, the Organising Committee may announce that presentation at the First Horse Inspection will be assumed to be a declaration to start.

3.3 WHEN there is a team classification, the Chefs d'Equipe must declare as part of the declaration of starters, in writing, the composition of the team, the starting order of the athletes within the team and, in the case of a team with three members, which starting position shall remain vacant.

3.4 WHEN an athlete has presented at the First Horse Inspection more horses than he is allowed to ride, he, or his Chef d'Equipe where applicable, must declare in writing the names of the horse(s) or horses definitely starting.

2010 RULES FOR EVENTING

4. Substitutions

After the Declaration of Starters, a change in the composition of a team or a change of which horse an athlete will ride must comply with the following:

4.1 THE SUBSTITUTION must be made at least one hour before the first athlete is scheduled to perform his dressage test on the day on which the athlete in question has been drawn to take part.

4.2 IN THE EVENT OF AN ACCIDENT OR ILLNESS OF AN ATHLETE, a certificate from an officially recognised doctor must be presented.

4.3 IN THE EVENT OF LAMENESS OR ILLNESS OF A HORSE, permission from the Veterinary Delegate must be obtained.

4.4 ANY HORSE that is to be substituted for a declared horse must have been presented and passed at the First Horse Inspection.

4.5 THE TECHNICAL DELEGATE, in consultation with the Ground Jury, must approve the substitution.

Article 511 REGISTRATION OF ATHLETES AND HORSES

1. Athletes

All athletes must be annually registered with the FEI.

2. Horses

2.1 ALL HORSES must be annually registered with the FEI.

2.2 EVERY HORSE entered at CCNs, CIC 2/1* and CCI 2/1* in a foreign country, and all horses entered at CIC 3* and CCI 4/3*, CCIOs, Championships, Regional and Olympic Games, whether at home or in foreign countries, must have an Official FEI Passport or a National Passport approved by the FEI, as a means of identification and to establish ownership.

2.3 HORSES taking part in CCNs, CIC 2*/1* and CCI 2*/1* in the country in which they are resident are not required to have such a passport as mentioned in Paragraph 2.2 above. All such horses must be properly registered with their NF and identifiable and, unless there is no national requirement for vaccination in the host country and in the country of origin, all horses must have a valid vaccination certificate.

Article 512 DRAW

1. Events with Individual Classification only

If there is only an individual classification, the draw will be conducted by the Organising Committee and the order of starting published in the programme.

2. Events with Team and Individual Classifications

2.1 WHEN there is a Team and an Individual Classification, a draw will take place to determine the nations order for the First and Third Inspection.

2010 RULES FOR EVENTING

This is also the team running order for athletes in the Dressage and Cross-Country Tests.

This draw will take place prior to the First Horse Inspection, in the presence of the Ground Jury, Technical Delegate and Chefs d'Equipe. All nations participating in the competition, whether by teams or individuals, will be included in this draw.

2.2 THE DETERMINATION of the starting order for the competition of all the athletes will be made after the First Horse Inspection, in the presence of the Ground Jury, Technical Delegate and Chefs d'Equipe, according to the following method:

2.3 THE TOTAL STARTING PLACES will be divided into eight blocks (A to H) and the athletes allocated to each block as follows:

- Block A: first athlete in each team
- Block B: 25% of individual athletes
- Block C: second athlete in each team
- Block D: 25% of individual athletes
- Block E: 25% of individual athletes
- Block F: third athlete in each team
- Block G: 25% of individual athletes
- Block H: fourth athlete in each team

The starting order within each team will be declared by its Chef d'Equipe. A team with only three members shall declare which starting position shall remain vacant. The team positions will be filled first. (If an athlete rides one horse in the team competition and one in the individual competition, then he must ride his team horse first.)

2.4 THE STARTING ORDER for the Individual athletes will then be determined as follows:

1. ATHLETES with a horse in the team competition, second horses will be placed by the Chefs d'Equipe in Block G, free choice in sequence according to the draw as per 2.1 above.

2. ATHLETES with 2 horses in the individual competition will be placed by Chefs d'Equipe in Block B and G, free choice in sequence according to the draw as per 2.1 above. Only one such athlete's horses may be placed by a Chef d'Equipe until his turn in the sequence recurs.

3. INDIVIDUAL athletes with one horse will now be positioned in any of the remaining unallocated starting places by their Chefs d'Equipe. At each turn in the sequence according to the draw in 2.1 above a Chef d'Equipe may place one horse in one of the blocks B, D, E, or G. The first individuals to be positioned (at this point) will be those without a representative team and this will take place in sequence according to the draw.

2.5 MORE than one member of a team will be permitted to ride two horses only if there are enough athletes in the event to allow both horses to be fitted into the time schedule in accordance with the above paragraph.

2010 RULES FOR EVENTING

3. Approval of Method of Draw

The method of draw must be approved by the Technical Delegate having consulted, if possible, with the Ground Jury. He may also approve rearrangement of the order or number of blocks of teams or individual athletes where the number of athletes makes it necessary.

Article 513 STARTING ORDER

1. At a Three Day Event the drawn starting order will be used for the Dressage and Cross-Country Tests.

2. The starting order in the Jumping Test must follow the reverse order of classification at the end of the Cross-Country Test. The lowest placed athlete will start first, and the last athlete to jump will be the one placed highest. If two horses ridden by the same athlete are classified within eight places of each other, the starting order of the lower placed must be adjusted.

3. At a CIC, the starting order will be drawn and this will be adhered to for the first two tests. The last Test, whether Show Jumping or Cross Country, may be run in reverse order of classification, at the discretion of the Organising Committee.

Article 514 TIMETABLE

1. Dressage Test

A timetable showing each athlete's starting time for the Dressage Test will be available to each athlete. The interval between starting times will be at the discretion of the Organising Committee, with the approval of the Technical Delegate.

2. Cross-Country Test

A timetable, showing each athlete's starting time for each phase, will be based on the optimum time for each phase. This timetable needs to be produced immediately after the end of the Dressage test. A copy will be available to each athlete. The interval between starting times will be at the discretion of the Organising Committee, with the approval of the Technical Delegate.

3. Jumping Test

A time schedule showing the start and the approximate finish of the Jumping Test shall be published. If the schedule is split, for example between morning and afternoon sessions, the number of athletes that will jump in the second session shall be noted.

4. CICs

Where two or more of the Tests take place on the same day, each horse must be allowed a minimum of 30 minutes between Tests.

2010 RULES FOR EVENTING

If the Cross Country takes place before the Show Jumping, there must be an interval of at least 1 hour between the finish of the Cross Country and the start of the show jumping for each horse.

Chapter II General Rules

Article 515 EXERCISING & WARMING-UP

1. Identification Number

Upon arrival, each horse is issued with an identification number, which must be worn at all times. It may be replaced by the draw number, which must then be worn until the end of the event. Failure to display either number incurs first a warning and, in the case of a repeated offence, a fine imposed on the athlete by the Ground Jury.

2. Restrictions on Schooling Horses

2.1 DURING THE THREE DAYS before the start of the First Horse Inspection or the Dressage Test as applicable and for the entire duration of an International Event, it is forbidden under penalty of disqualification for anyone to school a horse other than the athlete who will ride the horse in the competition.

2.2 A GROOM, while mounting, is not permitted to school the horse but only to hack it, exercise it or ride from one place to another. A groom may also work the horse in hand or on the lunge.

2.3 UNDER PENALTY of disqualification, riding close to cross-country obstacles, or riding in the dressage or jumping arenas prior to the actual competition is forbidden, unless specifically authorised by the Ground Jury or the Technical Delegate.

3. Exercise Areas

At International Events, appropriate areas suitable for the general exercise of horses must be made available and must be open throughout the hours of daylight. These should include tracks and areas for hacking and for galloping. The Organising Committee must inform athletes of the areas that are available for this purpose. Horses may be exercised only in such designated areas and/or in the practice areas for dressage and jumping.

4. Practice Dressage Arena

At least one practice arena of 60 by 20 meters must be put at the disposal of the athletes two days before the first day of the Dressage Test. If possible, this arena should be of the same consistency as the competition arena.

5. Practice Obstacles

The only practice obstacles that athletes may jump are those provided by the Organising Committee. The Organising Committee must provide at least two fixed practice obstacles which must be marked with red and white flags, of which the dimensions may not exceed those of the cross-country phase. ~~There shall be no practice obstacles available on the cross-country day between the start of Phase A and the finish of Phase D at events with~~

2010 RULES FOR EVENTING

~~Steeple Chase.~~ For any **all** competition without Steeple Chase there will be a practice warm-up area near the start of the Cross Country with both fixed and knock down obstacles, the specifications for the latter being as set out below.

JUMPING TEST: All obstacles must be marked with red and white flags. No part of the obstacle may ever be held by anyone. These obstacles may not be raised more than 10 cm above the height allowed in the Jumping Test. The spread may never exceed the maximum permitted. The practice obstacles shall only be jumped at times laid down by the Organising Committee. Violation of any of the above provisions relating to practice obstacles is forbidden, under penalty of disqualification (see "Rules for Jumping Events").

6. Stewards

One or more Stewards must be appointed to ensure that the rules regarding exercising and warming-up are obeyed. A Steward must be present at whatever times the Organising Committee has laid down that practice obstacles may be used. Other practice and exercise areas may be patrolled by Stewards in a random manner.

Article 516 ACCESS TO COURSES & ARENAS

1. Dressage Arena

Unless permission is given by the Jury, it is forbidden for athletes, under penalty of disqualification, to enter the arena mounted at any time other than when performing their test during the competition. The arena may be inspected on foot prior to the start or during breaks in the competition.

2. Cross-Country Courses

2.1 IT IS FORBIDDEN, under penalty of disqualification, to inspect the obstacles or the course before it is officially open to the athletes, unless agreed to by the Technical Delegate.

2.2 THE CROSS-COUNTRY COURSE will be opened to all athletes on the same day before the event begins.

2.3 ALL OBSTACLES, flags and markers that have to be observed by athletes shall be exactly in position when the course is opened to athletes. Thereafter, they may not be moved or altered by athletes under penalty of disqualification.

2.4 AFTER THE COURSE has been officially opened, athletes are allowed to revisit the course during the hours of daylight and examine the obstacles. This examination must take place on foot only, unless special permission is given by the Jury.

3. Jumping Course

3.1 THE COURSE FOR THE JUMPING TEST will be open to athletes not less than 30 minutes before the start of the Jumping Test.

2010 RULES FOR EVENTING

3.2 ATHLETES ON FOOT will be admitted to the arena before the Jumping Test. Permission to enter the arena will be given by the Ground Jury. An announcement must also be made over the public address system.

3.3 UNLESS PERMISSION is given by the Jury, it is forbidden for athletes, under penalty of disqualification, to enter the arena on foot once the competition has started.

Article 517 INTERRUPTIONS & MODIFICATIONS

1. Interruptions

The timetable may be interrupted due to dangerous conditions. If necessary, the start of any test or phase may be brought forward, postponed or cancelled. The decision to interrupt or cancel a test will be made by the President of the Ground Jury after consultation with the other Members of the Ground Jury and the Technical Delegate, if possible. In the case of an interruption, the event will be resumed as soon as possible at the point of the interruption. Every affected athlete must receive sufficient warning before the resumption of the competition.

2. Modifications

After the courses have been officially shown to the athletes, alterations may be made only when exceptional circumstances (such as heavy rain or hot weather) make obstacles or a test unfair or dangerous. The decision will be taken by the President of the Ground Jury after consultation with the other Members of the Ground Jury and Technical Delegate if possible. He is authorised to make any necessary changes to the test. In such cases, the Chefs d'Equipe and every athlete must be officially and personally informed of the alteration before the start of the phase or the test concerned. Where appropriate, an official must also be stationed at the place where the alteration has been made in order to warn the athletes.

Article 518 INSPECTION & EXAMINATION OF HORSES

1. Championships & CCIOs & CCIs

1.1 EXAMINATION UPON ARRIVAL - This takes place on the arrival of horses at the stables of the event. It is performed by a qualified veterinarian, normally the Associate Veterinarian, appointed by the Organising Committee. The object is to establish first each horse's identity and veterinary history (vaccination, etc.) and second, each horse's state of health (but not its soundness). The Organising Committee must fix the place and timetable for this examination in agreement with the Veterinary Delegate and inform in advance the Chefs d'Equipe and/or the individuals. Doubtful cases must be reported to the Ground Jury or Appeal Committee as appropriate, as soon as practicable and, in any case, before the First Horse Inspection.

1.2 FIRST HORSE INSPECTION - This takes place before the Dressage Test, normally the day before. It is conducted by the Ground Jury and the Veterinary Delegate acting together as a committee with the President of

2010 RULES FOR EVENTING

the Ground Jury in charge. The horses must be inspected in hand, at rest and in movement on a firm level, clean but not slippery surface. The committee has the right and the duty to eliminate from the competition any horse that they judge is unfit, whether on account of lameness, lack of condition or for any other reason. In a doubtful case the Ground Jury may direct that the horse be put in an officially supervised holding area for examination by the Associate Veterinarian. He will report any findings to the Ground Jury and the Veterinary Delegate, prior to the horse being re-inspected by the committee, should the athlete decide to represent the horse. Horses in the holding area will be under the supervision and control of the Associate Veterinarian. In the event of equality of votes within the committee, the President of the Ground Jury will have a second and casting vote, and the decision will be announced immediately.

1.3 CROSS COUNTRY - There will be a Veterinarian near the start of the Cross Country to report any doubtful cases to the Ground Jury.

1.4 EXAMINATION AFTER CROSS COUNTRY OBSTACLE TEST - This takes place after the athlete has finished the Cross Country. It is conducted by a qualified veterinarian appointed by the Organising Committee in agreement with the Veterinary Delegate. In addition to carrying out any immediate treatment required by an injured or exhausted horse, this veterinarian will decide if each horse:

1. Is fit to return immediately on foot to its own stable,
2. Should remain for further treatment before returning to its stable,
3. Should be transported by vehicle (which must be available) either direct to its stable or to a veterinary hospital.

This veterinarian has no authority to eliminate any horse from the competition, but must report any doubtful case to the Ground Jury and to the Veterinary Delegate.

1.5 SECOND HORSE INSPECTION - This takes place before the Jumping Test. It is conducted by the same committee and under the same conditions as the First Horse Inspection.

1.6 APPEAL - At the ~~three~~ **two** inspections where a horse may be eliminated from the competition, there can be no appeal against the decision of the committee concerned. However, if requested, the president must give a reason for the committee's decision after the completion of the whole inspection. The Veterinary Delegate will be a member of the committee present at these ~~three~~ **two** horse inspections.

1.7 DURING THE COMPETITION - At any other time during the competition, any individual member of the Ground Jury has the right and the duty to eliminate any horse, which in his opinion is lame or unfit to continue. An athlete who has withdrawn, been eliminated or stopped during the Cross Country for dangerous riding or abuse of Horse is responsible to present his/her horse if fit to walk back to the Stables to the Veterinary Delegate or an appointed Veterinary.

1.8 PUBLIC - The Horse Inspections shall be open to viewing by the public.

1.9 MEDICATION CONTROL TESTING / VETERINARY MANAGEMENT - A meeting of the Veterinary Delegate appointed for the CIC and

2010 RULES FOR EVENTING

representative(s) of the Organising Committee should take place well before the event to go through the veterinary management for the CIC.

The Organising Committee must provide adequate veterinary facilities including a suitable box for clinical examination and first aid, and a sampling box for medication control purposes.

Medication control testing should be carried out by an official Testing Veterinarian as part of the FEI's Medical Control Programme or by the Veterinary Delegate if the event is outside the MCP area (i.e. Groups I & II).

2. ~~CICs—exceptional alternative Horse Inspection procedures at all CIC competitions~~

~~If the event is organised on one or two days, and in exceptional circumstances and if agreed by Technical Delegate, an alternative procedure may be adopted:~~

~~**2.1—HORSE INSPECTION**—One Horse Inspection must take place before the Dressage Test is completed, according to the same format as for CCIs. Every horse must be inspected by the Veterinary Delegate or the Associate Veterinarian with at least one Member of the Ground Jury or another FEI listed Judge. Should a second Inspection be organised, the Members of the panel should be consistent with the 1st Horse Inspection.~~

~~If there is any doubt about the horse's fitness to compete, a member of the Ground Jury will make the final decision as to whether it can continue in the competition:~~

~~If a CCI and CIC competition are held together at the same venue, a horse that is not accepted at a CCI Horse Inspection cannot start in the CIC competition:~~

~~At all CIC competitions there must be an Official Horse Inspection, as per Article 518.1.2 for CCI's. The Horse Inspection must be published in the schedule, and must take place at an appointed time:~~

~~**2.1** Before the Dressage or Jumping test for CICs organised according to the Dressage-Jumping-Cross Country format.~~

~~**2.2** After Cross Country test and before the Jumping test for CICs organised according to the Dressage-Cross Country-Jumping (CCI) format (in this case Organisers may also include an additional first horse inspection before the Dressage test).~~

~~The specific provision take precedence over the FEI Veterinary Regulations however the general principles of the FEI Veterinary Regulations Art 1011 – "Horse Inspections" prevail.~~

Article 519 HORSE & ATHLETE WELFARE

1. Eventing Risk Management Vision statement

Eventing constitutes an exciting and challenging all-round test of riding ability and horsemanship within an accepted and acceptable level of risk. Every effort must be made to ensure that, at each level, responsible athletes are participating with progressively trained horses in order not to

2010 RULES FOR EVENTING

be exposed to a higher risk than which is strictly inherent to the nature of the competition.

2. Control of Medication of Horses

The Control of Medication of Horses must be conducted in accordance with the "General Regulations" and the "Veterinary Regulations".

3. Athlete Fitness & Medical card

It is compulsory that athletes, during the Cross-Country Test, carry visibly on their person a medical card including any relevant medical history of serious illness, injury (particularly to the head), tetanus immunity status, drug allergies, current medication and blood group. Organising Committees need to collect all athletes' Medical cards upon their arrival at the event. These cards must then be checked by the Organising Committee's Medical Officer. It is recommended that a copy be kept during the event by the OC Secretariat. Each athlete should also provide the contact numbers of two persons close to kin at this time.

Athletes are responsible to record all injuries on the Medical card.

4. Examination after a fall - Medical Fitness

4.1 IF there is any doubt with regard to fitness to compete the Ground Jury may with **Medical Advice** eliminated the athlete at its discretion.

~~A veterinarian and/or an Official Medical Officer as appropriate must examine all horses and athletes that have a fall during training or competition before they either take part in another test, event or leave the competition site (1st July 2009).~~

All Athletes that have had a fall during training or competition must be examined by the Official Medical Officer before they either take part in another test, competition or leave the event site. The athlete is fully responsible for ensuring that this examination takes place and in case of a horse fall, that the horse is examined by the Official Veterinarian.

4.2 ACCIDENTS INVOLVING ATHLETES - The following will apply to all registered athletes taking part in FEI Eventing competitions:

1. UNCONSCIOUSNESS AND/OR CONCUSSION: ~~In the event that~~ When an athlete has an accident that results in unconsciousness **and/or concussion**, the athlete must be automatically disqualified from the competition **and is ineligible to take part in any other test or competition at the event.**

~~**2. CONCUSSION.** In the event that an athlete has an accident that results in an apparent concussion, the athlete must be automatically disqualified from the competition.~~

~~**3. INJURY.** In the event that an athlete has an accident that results in an injury necessitating treatment by or admission to a medical facility, the athlete is ineligible to compete until a "Federation Release to Compete Form" is properly submitted to the competition at which he wishes to compete.~~

~~**4. MEDICAL SUSPENSION.** Any athlete who is disqualified from a competition or ineligible to compete under any of the preceding paragraphs will be~~

2010 RULES FOR EVENTING

placed on the Federation Medical Suspension List that will be posted on the Federation's website.

~~**5. RETURN TO COMPETITION.** In the event that an athlete is disqualified from a FEI competition under one of the preceding paragraphs, the athlete must submit a "Federation Release to Compete Form" certified by a physician in order to be eligible to once again compete in FEI competitions. Where applicable, the "Federation Release to Compete Form" must be certified by a physician who holds a current Board certification in the specific specialty for which the athlete was treated (e.g. a neurologist must provide certification if the athlete was treated by one).~~

~~**6.** (NFs may obtain the "**FEI RELEASE TO COMPETE FORM**" from the FEI Eventing Department).~~

~~**7. REFUSAL OF ENTRY.** Organisers shall refuse entries of any athlete who is on the Federation Medical Suspension List, unless he submits a proper Federation Medical Release Form as described in the preceding paragraph.~~

5. Control of Medication of Horses

The Control of Medication of Horses must be conducted in accordance with the "General Regulations" and the "Veterinary Regulations".

6. Elimination of Athlete after Dressage

If an athlete obtains an insufficient Dressage score further to lack of control of the horse, the Ground Jury has the responsibility to review the ability of the athlete and eliminate him/her if it is thought that this could lead to non control of horse during XC (a non-Qualifying results of 75 penalty points or more is not necessary related).

7. Dangerous Riding

1. ANY ATHLETE who affects the safety of any horse, athlete or third party will be considered to have acted dangerously and will be penalised accordingly (see Art 532.1.3).

2. AS SOON AS POSSIBLE, THE OFFICIAL WILL REPORT the incident to the Ground Jury, who will decide whether or not to penalize the athlete in accordance with Art 532.1.3.

3. THE GROUND JURY AND THE TECHNICAL DELEGATE have the authority to stop an athlete on cross country course for dangerous riding, riding an exhausted horse, excessive pressing of a tired horse, riding an obviously lame horse, excessive use of whip and/or spurs or riding in an unsafe way. Also refer to Art. 549.1.2. **549.1.12**

4. THE PRESIDENT OF THE GROUND JURY must in addition designate one or several Officials (i.e. TD, Chief Steward, experienced Eventing Officials not in an official function at the event) for the Cross Country to stop an athlete on course for dangerous riding, riding an exhausted horse, excessive pressing of a tired horse, riding an obviously lame horse, excessive use of whip and/or spurs or riding in an unsafe way. It is recommended that these additional officials be grouped as pairs on Cross Country.

Officials will be positioned with a flag to be waved at an athlete on the instruction of the Ground Jury to one of the appointed officials/fence judge,

2010 RULES FOR EVENTING

to stop the athlete if the situation continues or if the infringement of the above is deemed to be serious.

25 penalties are awarded to the athlete penalised for dangerous riding, if the athlete has finished the Cross Country. (See Art. 532.1.3)

A Yellow warning card can be given to an athlete after having been eliminated on the Cross Country course at the discretion of the Ground Jury. (See Art. 520.3 below)

Article 520 ABUSE OF HORSES AND DANGEROUS RIDING

(See also "General Regulations")

1. Any act or series of actions that in the opinion of the Ground Jury can be defined as abuse of a horse or dangerous riding shall be penalised by disqualification and such other penalties in accordance Art. 532.1 of the present Rules as the Ground Jury may determine. Such acts include, for example:

1. Rapping
2. Riding an exhausted horse
3. Excessive pressing of a tired horse
5. Riding an obviously lame horse
6. Excessive use of whip, bit and/or spurs (see para. 2 below)
7. Dangerous riding
8. Riding in an unsafe way or losing control of the horse
9. Series of dangerous jumps
10. Horses bleeding on the flank(s) or bleeding in the mouth, nose or marks indicating excessive use of the whip on the flank(s) or the horse's back, will result in disqualification. (In minor cases of blood in the mouth, such as where a horse appears to have bitten its tongue or lip – Officials MAY authorize, except during a test, the rinsing or wiping of the mouth and allow the rider to continue – any further evidence of blood in the mouth will result in disqualification)

Officials must report such actions as soon as possible to the Ground Jury through the Secretary of the Organising Committee or Control Centre of the event as appropriate, supported where possible by a statement from one or more witnesses. The Ground Jury must decide if there is a case to be answered.

Any individual member of the Ground Jury who observes such actions, has the right and the duty to disqualify the athlete forthwith on his own authority.

2. Whips

1. The whip cannot be used to vent an athlete's temper. Such use is always excessive
2. The whip is not to be used after elimination or after a horse has jumped the last fence on a course
3. The whip is never to be used overhand, (e.g. a whip in the right hand being used on the left flank). The use of a whip on a horse's head, etc., is always excessive use.

2010 RULES FOR EVENTING

4. A horse should never be hit more than three times for any one incident. If a horse skin is broken, its use is excessive

5. An athlete identified as misusing or excessive use of the whip will be eliminated at the discretion of the Ground Jury

3. Warning "Yellow" Cards

(See General Regulations Art. 169.7.2)

Should the same Person Responsible receive one more Warning "Yellow" card at the same or any other International Event within one year of the delivery of the first Warning "Yellow" card for the same offense, the Person Responsible shall automatically be suspended for a period of two (2) months immediately following the event at which the Person Responsible is competing. The Secretary General shall be responsible to notify the Person Responsible of such suspension.

Article 521 DRESS

1. Protective Headgear

Wearing a hard hat is compulsory for anyone riding a horse on the flat at the event.

Protective headgear complying with the European (EN), British (PAS), North American (ASTM), Australian/New Zealand tested standards is compulsory for anyone jumping an obstacle.

Failure to wear the appropriate headgear while riding on the flat or jumping any obstacle or with an incorrect or unfastened retention harness shall be penalised by elimination, at the discretion of the Ground Jury.

2. Whips

2.1 TRAINING: A whip no longer than ~~110cm (43.3 inches)~~ **120 cm** including lash may be carried when riding on the flat at any time. While jumping any obstacle before the Cross-Country and/or Jumping Test, a whip, if carried, must not be weighted at the end or exceed 75cm (30 inches) in length.

2.2 HORSE INSPECTION: Athlete may carry a whip if he wishes.

2.3 DRESSAGE TEST: ~~Carrying a whip of any kind during the Dressage test is forbidden, under penalty of elimination. The whip must be dropped before entering the space around the competition arena or the athlete will entail a penalty of 4 points per judge.~~

It is forbidden to carry a whip of any kind while competing in the arena. However, the use of one whip, with a total maximum length of 120 cm (Pony competitions maximum 100 cm), in the practice area is allowed. The whip must be dropped before entering the space around the competition arena or the athlete will entail a penalty.

All of the following are considered errors as Rules for Dressage Art. 430.3 & 430.4:

- Error of course or
- Entering the space around the arena with whip or

2010 RULES FOR EVENTING

- Entering the dressage arena with whip or
- Not entering the arena within 45 seconds after the bell or
- Entering the arena before the sound of the bell

First error	2 Points
Second error	4 Points
Third error	Elimination

2.3 CROSS COUNTRY AND JUMPING: If a whip is carried in the Cross Country and/or Jumping Test, it must not be weighted at the end or exceed 75 cm (30 inches).

3. Spurs

Spurs capable of wounding a horse are forbidden. Spurs must be of smooth metal. If there is a shank it must not be more than 3.5 cm long and must point only towards the rear, Rowels are ~~not~~ **only** permitted **for dressage**, ~~except~~ as per 5.5. below. The end of a **the** shank must be blunt ~~in order~~ to prevent wounding a horse. If the shank is curved, the spurs must be worn only with the shank directed downwards. Metal or plastic spurs with round hard plastic or metal knobs ~~are allowed~~ ("Impulse" spur) **and** "Dummy spurs" with no shank are allowed.

See para 5.5 for exception for Dressage Test.

4. Boots

In all Tests, boots (other than as part of regulation service dress) must be black, brown or black with a brown top. They must either be long boots in one piece or a full grain smooth leather leg piece and leather boot.

5. Dressage Test

5.1 CIVILIAN – compulsory except as indicated in 5.2 & 5.3 below: hunting dress or uniform of a riding club, white shirt and tie, gloves, white, fawn or cream breeches, boots, hunting cap, protective headgear or top hat, and spurs (in accordance with Para. 3 above)

5.2 AT CICS 2/1* athletes, if they wish, may wear a tweed jacket with fawn or beige breeches and black or brown boots.

5.3 AT CCI/CIC1* the wearing of a top hat and tailcoat is not encouraged.

5.4 MEMBERS OF ARMED AND POLICE FORCES, members and employees of military establishments and national studs - compulsory: service dress and gloves, regulation headgear and spurs (in accordance with Para. 3 above).

5.5 SPURS - In the CIC/CCI1* tests, spurs are not compulsory.

~~Rowels~~ Spurs **with rowels** are allowed for the Dressage Test and when practicing / warming up for dressage. If rowels are used, they must be free to rotate and **the** rowel must be round and smooth (no tines allowed).

2010 RULES FOR EVENTING

6. Cross-Country Test

Light-weight clothing is appropriate for this test. Protective headgear, in accordance with Para. 1 above. Back protectors must be worn. Spurs are optional; if used, they must be in accordance with Para. 3 above.

7. Jumping Test

7.1 CIVILIAN - hunting dress or uniform of a riding club, white shirt and tie, white, fawn or cream breeches, boots. Spurs are optional but, if used, must be in accordance with Para. 3 above.

7.2 At CIC 2/1*, athletes, if they wish, may wear a tweed jacket with fawn or beige breeches and black or brown boots.

7.3 MEMBERS OF ARMED AND POLICE FORCES, members and employees of military establishments and national studs - service dress. Spurs are optional; if used they must be in accordance with the Para. 3 above.

7.4 IN EACH CASE, a protective headgear, in accordance with Para. 1 above, must be worn.

8. Advertising and Publicity on Athletes & horses

Subject to the provisions of article 135 of the General Regulations, the manufacturer logo can appear:

1. 3cm² once per item - therefore ok on any clothing item - breeches, gloves, shirt, helmet for the Dressage, Cross Country and Jumping tests
The Individual sponsor logo may appear:
 1. 80cm² on each of the two sides of jackets at the height of breast pockets for Dressage & Jumping tests
 2. 200cm² on arm of top garment for Cross country"

For the Jumping and Cross country test, athletes are allowed to bear the logo of their sponsor vertically in the middle of their hard hat. The said logo must not be longer than 25cm or wider than 5 cm."

9. Inspection of Dress

9.1 A STEWARD can be appointed to inspect whips and spurs before any test. He has the authority to refuse permission for any athlete to start, whose whip or spurs contravene this article. He will immediately report the circumstances to the Ground Jury for confirmation.

9.2 AN ATHLETE who competes with illegal whip(s) ~~or spurs~~ will be ~~eliminated~~ penalised according to Art 521.2. An athlete who competes with illegal spurs or with incorrect items of dress is liable to elimination, at the discretion of the Ground Jury.

2010 RULES FOR EVENTING

Article 522 SADDLERY

1. Exercise Areas

The following are compulsory: an English type saddle and any form of bridle, including double bridle, snaffle, gag or hackamores. Running martingales (with snaffle only), Irish martingales, bit guards, boots, bandages, fly shields, nose covers and saddle covers are permitted. Single direct side reins are permitted only while lunging (only with one lunge line) as are running reins and chambons. Other martingales, any other kind of gadget (such as bearing, side or balancing reins, etc.) and any form of blinkers, are forbidden, under penalty of disqualification.

2. Dressage Test

2.1 THE FOLLOWING ARE COMPULSORY: an English type saddle and a permitted bridle.

2.2 A DOUBLE BRIDLE with cavesson noseband i.e. bridoon and curb with curb chain (made of metal or leather) is permitted, as authorized by the Rules for Dressage. Double bridle is not allowed for CCI/CIC 1*.

2.3 A SNAFFLE BRIDLE of which the bit is made of metal, leather, rubber or plastic material is also permitted as authorized by the Rules for Dressage. It must be made entirely of leather, except for a small disc of sheepskin, which may be used in the intersection of the two leather straps of a crossed noseband. For drawings of permitted bits and nosebands, see Annex 1. Certain tests may specify that only a snaffle bridle is allowed.

2.4 MARTINGALES, bit guards, any kind of gadgets (such as bearing, side, running or balancing reins, etc.), any kind of boots or bandages and any form of blinkers including earmuffs, earplugs, hoods, fly shields, nose covers and saddle covers, are under penalty of elimination, strictly forbidden in accordance with the Dressage rules. A breast plate may be used. However, under exceptional circumstances, fly hoods or shields may be permitted by the Ground Jury for all competitors, solely in order to protect horses from insects. False tails are permitted provided they are not weighted or otherwise "enhanced" in any way whatsoever.

3. Cross-Country Test & Jumping Test

3.1 THE TYPE OF SADDLERY is optional. Gags or "bitless bridles" are allowed as are unrestricted running martingales or Irish martingales. Reins must be attached to the bit(s) or directly to the bridle. **Sheepskin (or other material) may not be used as addition on cheek pieces of the bridle.** The stirrup iron and stirrup leathers must hang free from the bar of the saddle and outside of the flap.

3.2 THE FOLLOWING ARE FORBIDDEN: any form of blinkers, side, running or balancing reins; tongue straps and /or tying down the horse's tongue; any other restrictions, any bit or other item of saddlery likely to wound a horse.

2010 RULES FOR EVENTING

4. Inspection of Saddlery

4.1 A STEWARD can be appointed to check the saddlery of each horse before it enters the arena or starts a test.

4.2 IN THE DRESSAGE TEST, the checking of the bridle must be done with the greatest caution. If the competitor so requests, the bridle and bit may be checked immediately after the test has been completed. However, should the bridle or bit in such a case be found not to be permitted, the competitor shall be eliminated by the Ground Jury.

Chapter III Dressage Test

Article 523 RULES FOR DRESSAGE EVENTS

The "Rules for Dressage Events" apply for Eventing Dressage except where otherwise provided in these rules. Any modification introduced by the FEI Dressage Committee during the year will be evaluated for inclusion in these Rules for Eventing from 1st January the following year.

Article 524 THE NATURE OF DRESSAGE TEST

1. The nature of the Dressage Test will be determined by the level of the Event and will, therefore, be related to the quality and the standard of preparation of the athletes and horses. 4 Within the limits shown in Annex 4-2, Organising Committees are free to select the specific test to be used.

At Games, Championships and Cup Finals the dressage test to be used will be decided by the FEI.

1. A DRESSAGE TESTS would apply for all championships all **star** levels in uneven years.

2. B DRESSAGE TESTS would apply for all championships of all star levels in even years.

Exception: however, for Junior Championships only the "B" test will be used.

2. Number of Tests to be judged by day

The Organiser may include a maximum of 50 horses per day to be judged by one Ground Jury, with an additional flexibility of maximum 10%, if agreed by the Technical Delegate and President of Ground Jury.

Article 525 JUDGES POSITION

Two of the three judges must be placed along the short side, on the outside of and 5 metres from the arena. The president (C) shall be on the prolongation of the centre line, the other (M or H) 2.50 metres from and on the inside of the prolongation of the long sides. The third judge will be at either E or B, outside and 5 – 10 metres from the arena. The three positions shall be either C,H,B or C,M,E, as determined by the Technical Delegate, taking into account the positions recommended for each test. At a CIC, the two judges will be positioned at C and either B or E, as determined by the Technical Delegate, taking into account the recommended position(s) for each test. A separate hut must be provided for each judge. They must be raised not less than 50 cm above the ground, in order to give the judges a good view of the arena.

2010 RULES FOR EVENTING

Article 526 SCORING

1. Marking

1.1 JUDGES will award good marks from 0 to 10 for each numbered movement and for each of the collective marks.

1.2 ERRORS of course or test will be penalised as follows:

1st time 2 points

2nd time 4 points

3rd time elimination

1.3 IN THE CASE of a fall of horse and/or athlete, the athlete will not be eliminated. He will be penalised by the effect of the fall on the execution of the movement concerned and in the collective marks (No 3 and/or No 4).

1.4 AFTER ELIMINATION (except when eliminated for marked lameness), an athlete may continue his performance to the end. The marks will be awarded in the ordinary way.

2. Calculation of Scores

2.1 THE GOOD marks from 0 to 10 awarded by each judge to an athlete for each numbered movement of the Dressage Test together with the collective marks are added together deducting any error of course or test.

2.2 FOR EACH judge the percentage of maximum possible good marks obtainable is then calculated. (Percentage is obtained dividing total good marks of the judge (minus any error of course or test) by maximum possible good marks obtainable and then multiplying by 100 and rounding the result to two decimal digits. This value is shown as the individual mark for that judge. (Rounding the result to 2 decimals includes any score of x.xx5 and above is round up and any score less than x.xx5 in rounded down).

2.3 AVERAGE PERCENTAGE for the athlete is obtained by adding together the percentage for each judge and dividing by the number of judges always rounding the result to two decimal digits.

2.4 IN ORDER to convert average percentage into penalty points, this must be subtracted from 100 and multiplied by 1.5, with the resulting figure being rounded to one decimal digit. The result is the score in penalty points for the test (Rounding the result to one decimal includes any score of x.x5 and above is round up and any score less than x.x5 in rounded down).

Chapter IV Cross-Country Test

Article 527 OBJECT

1. Cross Country

~~This test is to prove the ability of the true cross country horse when it is well trained and brought to the peak of condition. At the same time, it demonstrates the athlete's knowledge of pace and the use of his horse.~~

The Cross Country Test constitutes the most exciting and challenging all-round test of riding ability and horsemanship where correct principles of training and riding are rewarded. This test focuses on the ability of athletes and horses to adapt to different and variable conditions of the competition (weather, terrain, obstacles, footing, etc.) showing jumping skills, harmony, mutual confidence, and in general "good pictures".

Article 528 CROSS COUNTRY

1. CCI Event

In the Cross Country Obstacle phase the course is of such a length that the horse is still required to be supremely fit and stamina will be required for success. The test will always take place before the Show Jumping.

2. CIC Event

In a CIC Event the test is of a similar level of difficulty, according to the star system, but the course is shorter. The Cross Country test may take place either before or after the Show Jumping.

Article 529 RULES GOVERNING THE CROSS COUNTRY TEST

1. Starting

1.1 ATHLETES at the start of the Cross Country Obstacles phase must be under the control of a starter and may not deliberately start until instructed to do so, under penalty of elimination, at the discretion of the Ground Jury. The horse does not have to stand absolutely immobile, but the athlete must not get any advantage from a flying start. Each athlete should be given reasonable warning before the time he is due to start, but it is the athlete's responsibility to ensure that he is ready to start at the correct time.

1.2 IN ORDER to simplify the task of the starter, an enclosure approximately 5 X 5 m will be built at the start of Cross Country, with an open front through which horses will start and a gap in one or both sides from which the horses will enter. Each athlete must start from within the enclosure and is at liberty to move around and through the enclosure as he pleases. An attendant may lead the horse into the enclosure and may hold the horse until the signal to start is given. From that instant, the athlete is

2010 RULES FOR EVENTING

considered to be on the course and no further assistance may be given (see Art. 529.8).

1.3 IF AN ATHLETE starts early on Cross Country, his time will be recorded from the moment he crossed the start line.

1.4 LATE FOR START - If for any reason an athlete is not ready to start Cross Country at his correct time, he may be allowed, at the discretion of the starter, to start when he is ready, subject to the following conditions:

1. A late athlete will not be permitted to start if he is likely to interfere with the subsequent athlete nor may he start after the subsequent athlete.
2. His starting time will be recorded as if he had started at the correct time.

2. Time

2.1 OPTIMUM TIME - the distance chosen, carried out at the chosen speed, gives the optimum time. Completing in less than the optimum time is not rewarded. An athlete exceeding the optimum time will be penalised in accordance with Art. 532.2 up to the time limit. The time limit is twice the optimum time.

2.2 TIMING OF THE CROSS-COUNTRY TEST - if an athlete is stopped on any of the phases by an official, e.g. for a broken fence, accident, being overtaken, for medical or veterinary examination, etc., the time during which he is prevented from continuing until he is cleared to start will be recorded and deducted from the total time taken to complete the phase.

3. Error of Course

All compulsory passages on Cross Country and all obstacles, including all elements and/or options, must be passed or jumped in order under penalty of elimination. All red or white flags must be respected wherever they occur on course, except as provided in Art. 533.5, under penalty of elimination, at the discretion of the Ground Jury. Retaking an obstacle already jumped is forbidden, under penalty of elimination, except as provided for in Art. 533.5.

4. Pace & Dismounting

Between the start and finish of the Cross Country, athletes are free to choose their own pace. ~~They must be mounted to pass all red and white boundary flags. Dismounting as a result of attempting an obstacle, whether voluntary or not, is penalised in accordance with Art. 533. Elsewhere on the courses,~~ Athletes may voluntarily dismount **without incurring elimination according to Art. 533 to check on horse, adjust saddlery or equipment.** ~~without incurring a fault other than possible penalties for exceeding the optimum time.~~

5. Overtaking

5.1 ANY ATHLETE who is about to be overtaken by a following athlete must quickly clear the way. Any athlete overtaking another athlete must do so only at a safe and suitable place.

2010 RULES FOR EVENTING

5.2 WHEN THE LEADING ATHLETE is before an obstacle and about to be overtaken, he must follow the directions of the officials. When the leading athlete is committed to jumping an obstacle, the following athlete may jump that obstacle only in such a way that will cause no inconvenience or danger for either.

5.3 THE PENALTY FOR WILFUL OBSTRUCTION of an overtaking athlete, failure to follow the instructions of the officials, or causing danger to another athlete is elimination at the discretion of the Ground Jury.

5.4 THE TIME DURING WHICH THE ATHLETE is held up by officials will be recorded and deducted from the total time taken by the athlete to complete the course.

6. Athletes in Difficulty

6.1 IF, in attempting to negotiate an obstacle, a horse should be trapped in such a way that it is unable to proceed without assistance or is liable to injure itself, the athlete will be instructed by the fence judge to dismount and will be eliminated.

6.2 THE FENCE JUDGE will decide if parts of it need to be dismantled or if any other assistance needs to be given to extricate the horse.

7. Stopping Athletes

7.1 IF ANY PART OF AN OBSTACLE is obstructed by an athlete in difficulty, or if any obstacle has been dismantled to release a fallen horse, or if an obstacle has been broken and is not yet rebuilt, or in any other similar circumstances, subsequent athletes must be halted.

7.2 IN SUCH A CASE, an official should be posted in the path of an oncoming athlete. He shall wave a red flag, which indicates that the athlete must stop. Failure to stop is penalised by elimination at the discretion of the Ground Jury.

7.3 ATHLETES may be stopped at obstacles or at Stopping Points on the course.

7.4 THE OFFICIAL will stop athletes only upon the instruction of the Control Centre or during an emergency at his own obstacle.

7.5 THE TIME during which the athlete was stopped, from the moment he passed the Stopping Point until he re-passed that same point after being given the order to restart, will be recorded. It will be deducted from the total time taken by the athlete to complete the course. It is clearly intended that the time shall be taken as the athlete gallops past the Stopping Point, not after he halts nor after a start from the halt.

8. Unauthorised Assistance

8.1 ANY INTERVENTION by a third party, whether solicited or not, with the object of facilitating the task of the athlete or of helping his horse, is considered unauthorised assistance and the athlete is liable to be eliminated.

8.2 IN PARTICULAR, the following are forbidden:

1. intentionally to take a lead from another athlete;

2010 RULES FOR EVENTING

2. to be followed, preceded or accompanied, on any part of the course, by any vehicle, bicycle, pedestrian, or horseman not in the competition;
3. to post friends at certain points to call directions or make signals in passing;
4. to have someone at an obstacle to encourage the horse by any means whatsoever;
5. to tamper with the obstacles or any part of the course, including, for instance, flags, indicators, markers, notices, ropes, trees, branches, wire or fences, whether temporary or permanent.

8.3 THE USE OF ANY ELECTRONIC receiving apparatus by athletes is strictly forbidden, while mounted during competition.

8.4 OFFICIALS OR SPECTATORS who draw the attention of an athlete to a deviation from the course are giving unauthorised assistance which may result in the elimination of the athlete. In such a case, an official is liable to be disciplined according to the "General Regulations".

8.5 ANY CASE of unauthorised assistance will be decided by the Ground Jury.

8.6 EXCEPTIONS

~~1. AFTER A FALL~~ or if an athlete dismounts, he may be assisted to catch his horse, to adjust his saddlery, to remount or be handed any part of his saddlery or equipment while he is dismounted or after he has remounted.

1. WHIP, HEADGEAR OR SPECTACLES may be handed to an athlete without dismounting.

2. AN ATHLETE may receive clarification of jumping penalties from the Fence Judge, e.g. after having knocked a flag at the corner of obstacle.

9. After Elimination

An athlete eliminated for any reason must leave the course at once and has no right to continue. The athlete must walk his horse off the course, either mounted or dismounted. Violators shall be warned or fined, at the discretion of the Ground Jury, in accordance with the "General Regulations" & Art. 520 of these Rules.

10. Closed circuit Television

The provision of closed circuit television of the Cross Country Obstacle test in the athlete enclosure of the start Box and at the control Centre for the use of the Ground Jury and Control Officials is mandatory for all Four Star International Three Day Events (CCI4*) and Four and Three star Championships (CH-C 4/3*). If this is impractical, the OC may, with the support of the Technical Delegate, apply to the FEI for this requirement to be waived.

Article 530 COURSES

1. Marking

1.1 RED OR WHITE BOUNDARY FLAGS - Red or white boundary flags shall be used to mark the starting and finishing lines, to mark compulsory

2010 RULES FOR EVENTING

passages, and to define obstacles. They are placed in such a way that an athlete must leave a red flag on his right and a white flag on his left.

1.2 YELLOW DIRECTIONAL MARKERS - Yellow directional markers shall be used to show the general direction to be taken and to help the athlete to find his way. Where necessary, they shall be superimposed with the letter of the phase. Passing close to them is not obligatory.

1.3 NUMBERS & LETTERS - Each obstacle on Cross Country shall be numbered. Obstacles with elements or options (see Art. 531.2) shall, in addition, be lettered (A, B, C, etc.). Each compulsory passage shall be marked with the relevant letter of the phase and numbered consecutively.

1.4 START & FINISH SIGNS - In addition to the red or white boundary flags, the starting and finishing line of each phase shall also be marked by distinct signs.

2. Distances & Speeds

2.1 THE DISTANCES AND THE SPEEDS demanded are determined by the intended difficulty of the whole test. Within the limits shown in Annex 5-3b, Course Designers may, with the approval of the Technical Delegate, choose the distances most suitable to the terrain and to the quality and standard of preparation of the athletes.

2.2 ANY MODIFICATION to the distances and speeds specified in Annex 5 must be approved by the Secretary General and by the Chairman of the Eventing Committee, except as provided for in Art. 517.2.

3. Finishing Lines

The last obstacle of Cross Country shall be not less than 30 metres no more than 75 metres from the finishing line.

4. Course Plans

4.1 EACH ATHLETE will be given in advance a plan showing the track of the course.

4.2 THE PLAN must include the following: the position of the start and finish; the numbered obstacles and compulsory passages; the distance; the optimum time and time limits.

Article 531 OBSTACLES

1. Definition

An obstacle is considered as such if and only if its extremities are marked with a red and white flag or flags and it is numbered. All significant jumping efforts that the average horse may be expected to attempt to negotiate must be defined as an obstacle or element and flagged, numbered and/or lettered accordingly.

2. Obstacles with Elements or Options

2.1 OBSTACLES COMPOSED OF SEVERAL ELEMENTS - If two or more jumping efforts, sited closely together, are designed as one integral test, they will be designated as "elements" of a single numbered obstacle. Each element

2010 RULES FOR EVENTING

will be marked with a different letter (A, B, C, etc.) and must be negotiated in the correct order.

Where two or more jumping efforts are sited so closely together that after a refusal, **or** run-out ~~or fall~~ it would be unreasonably difficult to attempt to negotiate the second or subsequent effort without retaking one or more earlier efforts, these jumping efforts must be designated as one numbered obstacle and lettered accordingly (Diagram, Annex 3 5).

2.2 OBSTACLES WITH OPTIONS OR ALTERNATIVES - Where an obstacle may be jumped in one effort but has options involving two or more efforts, each of these options must be lettered as an element.

2.3 ALTERNATIVE OBSTACLES OR ELEMENTS may be flagged separately and must be identified by the same number/letter as on the direct route. In this case both sets of flags must be marked with a black line. Such 'black flag' alternatives are to be judged as separate obstacles or elements, only one of which has to be jumped. An athlete is permitted to change without penalty from one black flagged line to another (e.g. jumping 6a left hand route then 6b right hand route) provided he has not presented his horse at the next element of the original line.

3. Type of Obstacles

3.1 THE OBSTACLES must be fixed and imposing in shape and appearance. When natural obstacles are used, they should, if necessary, be reinforced so that they remain in the same state throughout the test. All reasonable precautions must be taken to prevent the possibility of an athlete being able to pass mounted under an obstacle. Portable fences must be secured to the ground in a way that the fence cannot move.

3.2 THE CROSS-COUNTRY OBSTACLES at which a horse, in falling, is likely to be trapped or to injure itself, must be built in such a way that part of the obstacle can be quickly dismantled and can be quickly rebuilt exactly as before. Such a construction must not in any way detract from the solidity of the obstacle.

3.3 IN ALL WATER CROSSINGS, the bottom should be firm and consistent.

3.4 BRUSH ON TOP OF FENCES must be measurable and be made of flexible and deformable material.

4. Number of Jumping Efforts

4.1 THE NUMBER OF JUMPING EFFORTS shall be within the limits shown in Annex 5 3b.

4.2 TO ARRIVE at the number of jumping efforts, the efforts on the route expected to be taken by the average horse shall be totalled.

5. Dimensions

5.1 THE DIMENSIONS OF OBSTACLES must be within the limits shown in Annex 4 for the relevant level of competition.

5.2 THE FIXED AND SOLID PART of an obstacle may not exceed the specified height or spread at any of the points at which an athlete might reasonably attempt to negotiate the obstacle.

2010 RULES FOR EVENTING

5.3 AT OBSTACLES involving water crossings (ford, lake or wide river), the depth of water, from the entrance to the exit must not exceed 35 cm. The length of any water crossing must be at least 6 meters between entry and exit, except where an exit step(s) or fence is jumped directly out of the water, in which case the minimum length must be 9 meters.

5.4 AT OBSTACLES with spread only (dry or water-filled ditch), a guard rail or hedge in front that facilitates jumping is permitted. It may not exceed 50 cm in height and must be included in the measurement of the spread.

5.5 THE NUMBER OF OBSTACLES at Four, Three and Two Star Events with a compulsory drop exceeding 1.60m is limited to two. At One Star Events, no compulsory drops over 1.60 metre are permitted.

6. Measurement

6.1 THE HEIGHT of an obstacle is measured from the point where the average horse would take off. The spread of an open obstacle (e.g. Oxer or Ditch) is measured from the outside of the rails or other material making up the obstacle. The spread of a closed obstacle with a solid top (e.g. Tables) is measured from the highest point to the highest point.

6.2 OBSTACLES of the Cross-Country Test: the maximum height of the fixed and solid part of a hedge or brush fence must never exceed the dimensions specified in Annex 3A - Table of Obstacle Heights and Spreads. The overall height of a hedge or brush fence must never exceed to the dimension set in table in Annex 3. The fence must be constructed so that a horse clearing the fixed and solid part is unlikely to be injured by the brush or hedge. Bullfinches, i.e. thin brushes or hedges through which a horse can be expected to jump are permitted, provided they can be maintained in consistent condition throughout the test (explanation on measurements – see Annex 3B).

6.3 WHEN THE HEIGHT of an obstacle cannot be clearly defined (natural hedge or brush fence), the height is measured to the fixed and solid part of the obstacle through which a horse cannot pass with impunity.

6.4 THE DROP on the landing side of an obstacle is measured from the highest part, including from the top of a brush fence, of the obstacle to the spot where the average horse would land.

Article 532 SCORING

1. Faults at Obstacles

1.1 REFUSAL, RUN-OUT OR CIRCLES

First refusal, run-out or circle	20 penalties
Second refusal, run-out or circle at the same obstacle	40 penalties
Third refusal, run-out or circle on XC Course	elimination
Breaking a frangible obstacle/device	25 penalties*

Ground Juries have the discretion to decide if the 25 penalties apply, when such device, deformable structure or any obstacle breaks (without a

2010 RULES FOR EVENTING

fall of horse & rider). As a reminder, Appeals are not admissible against decisions by the Ground Jury in relation to dangerous riding.

FALLS

Fall of athlete and/or horse on Cross Country Course elimination

1.3 DANGEROUS RIDING (SEE ART 519 & 520)

Penalties will be determined by the Ground Jury in accordance with the General Regulations; in addition to or instead of the penalties prescribed by the General Regulations (Yellow Warning card, Fine, Disqualification, etc) the Ground Jury may penalise the athlete with 25 penalties.

25 penalties awarded for dangerous riding will count as obstacle penalty on the Results.

2. Time Faults

2.1 EXCEEDING OPTIMUM TIME - 0.4 penalty per commenced second

2.2 EXCEEDING TIME LIMIT - Elimination

3. Additional Reasons for Elimination

3.1 ELIMINATION is left to the discretion of the Ground Jury in the following cases:

1. **DELIBERATELY** starting before being given the signal to start, Art. 529.1.1
2. **JUMPING** or attempting to jump any obstacle without headgear, or with an unfastened retention harness, Art. 521.1
3. **WILFUL** obstruction of an overtaking athlete, or failure to follow the instructions of the officials while being overtaken, Art. 529.5.3
4. **CAUSING** danger to another athlete while overtaking that athlete, Art. 529.5.3
5. **FAILURE** to stop when signalled, Art. 529.7.2
6. **UNAUTHORISED** assistance, Art. 529.8.1
7. **PASSING** through a compulsory passage in the wrong direction without correction, Art. 529.3
8. **DANGEROUS** riding Art 520

3.2 ELIMINATION must be applied in the following cases:

1. **ABUSE** of horse, Art. 520
2. **COMPETING** with improper saddlery, Art. 522.3
3. **ERROR** of course not rectified, Art. 529.3
4. **OMISSION** of obstacle or compulsory passage, Art. 529.3
5. **JUMPING** or incurring a fault at an obstacle in the wrong order or passing through a compulsory passage in the wrong order, Art. 529.3
6. **JUMPING** an obstacle in the wrong direction, Art. 529.3
7. **RETAKING** an obstacle already jumped, Art. 529.3.
8. **ATHLETE** in difficulty Art 529.6.1

2010 RULES FOR EVENTING

Article 533 DEFINITIONS OF FAULTS

The following faults at obstacles (refusal, run-out or circle fault) will be penalised unless, in the opinion of the responsible official, they are clearly not connected with the negotiation or attempted negotiation of a numbered obstacle or element.

1. Refusal

At obstacles or elements with height (exceeding 30 cm), a horse is considered to have refused if it stops in front of the obstacle to be jumped.

At all other obstacles (i.e. 30 cm or less in height) a stop followed immediately by a standing jump is not however penalised, but if the halt is sustained or in any way prolonged, this constitutes a refusal. The horse may step sideways but if it steps back, this is a refusal.

After a refusal, if an athlete redoubles or changes his efforts without success, or if the horse is represented at the obstacle after stepping back and stops or steps back again, this is a second refusal; and so on.

2. Run-out

2.1 A HORSE is considered to have run out if, having been presented at an element or obstacle on the course, it avoids it in such a way that the head and neck of the horse and the head of the athlete when mounted fail to pass between the extremities of the element or obstacle as flagged.

2.2 AN ATHLETE will also be penalised 20 penalties if the horse disobediently avoids that part of the fence at which it has been presented, but succeeds in negotiating the obstacle at some other part, between the flags. However an athlete is permitted to change his mind as to where he jumps an obstacle or element at any time, without penalty, including as a result of a mistake at a previous obstacle or element. If, however, the horse avoids part of the obstacle at which it has been presented, 20 penalties are incurred.

2.3 JUDGING OF BOUNCE OBSTACLES - At any obstacle where the distance between elements is 5 meters or less (i.e. a 'bounce'), when a horse has negotiated the first element without penalty, he will be deemed to have been presented at the second element – and similarly if the "bounce" is for example the second and third elements of a combination. Thus if an athlete "changes his mind" while negotiating the first element of a "bounce" and , for example, then goes a longer route, he will still be penalised 20 penalties for a run-out.

3. Circle

3.1 AT AN OBSTACLE composed of several elements (A, B, C, etc...) a horse will be penalized if it passes around any element or circles between elements at any time between first being presented at the obstacle and finally completing the last element. See updated diagrams in Annex 5 (see Art. 531.2.3).

3.2 AFTER being penalised for a refusal, run-out or circle, an athlete is permitted to cross his original track without penalty in order to make

2010 RULES FOR EVENTING

another attempt and may also circle one or more times without penalty, until he again presents his horse at the obstacle.

3.3 AT SEPARATELY numbered obstacles, an athlete may circle between or around them without penalty provided he has not presented his horse at the second or subsequent obstacles.).

4. Fall

4.1 AN ATHLETE is considered to have fallen when he is separated from his horse in such a way as to necessitate remounting or vaulting into the saddle.

4.2 A HORSE is considered to have fallen when at the same time both its shoulder and quarters have touched either the ground or the obstacle and the ground or when it is trapped in a fence in such a way that it is unable to proceed without assistance or is liable to injure itself.

5. Obstacle composed of Several Elements

At an obstacle composed of several elements, an athlete may refuse, run out and/or circle only twice in all without incurring elimination. If he refuses, runs out or circles at any element, he is permitted to retake any elements already jumped, although he is liable to be penalised for any fault even if he has previously jumped an element successfully. If after a refusal, run-out or circle, he wishes to pass through flags in the wrong direction in order to retake an element, he may do so without penalty.

6. Instruction to Officials

Where there is any doubt as to the correct interpretation of the rules of judging any element, obstacle or combination of obstacles, it is recommended that the Technical Delegate, in consultation with the Ground Jury if possible, should approve the instructions to the Officials, providing a rough sketch if necessary, and all athletes will be informed at the briefing or as soon as possible after the Technical Delegate's decision, if later.

Chapter V Jumping Test

Article 534 RULES FOR JUMPING EVENTS

The "Rules for Jumping Events" apply for Eventing Jumping except where otherwise provided in these rules. Any modification introduced by the FEI Jumping Committee during the year will be evaluated for inclusion in these Rules for Eventing from 1st January the following year.

Article 535 OBJECT & GENERAL DESCRIPTION

1. This test is similar to an ordinary show jumping competition, but without any attempt to find a 'winner' of this test on its own. Its main objective is to prove that, the horse and athlete are well trained in the specialist discipline of Show Jumping.

2. The nature of the course, its length, the speed demanded and the dimensions of the obstacles depend on the degree of difficulty of the whole competition.

Article 536 SIZE OF ARENA

As an exception to Article 201 of FEI Rules for Jumping, the arena must be enclosed. While a horse is in the arena during a competition, all entrances and exits must be physically closed. Any arena of less than 4,000 sq m and/or less than 50m wide on the short side must be specifically notified to the FEI and approved by the Technical Delegate before the schedule for the event is approved.

If the arena is less than 5000 square meters, the maximum speed for Three and Four star events shall be 350 meters/min.

In arenas less than 2300 square meters the maximum speed for any level shall be 325 meters/min.

Article 537 COURSE - OBSTACLES

1. Distance & Speed

Within the limits shown in Annex 5, the Course Designer is free to plan a track suitable to the level of the competition. In exceptional circumstances it is permissible, with the approval of the Technical Delegate and Ground Jury to add up to 10% of the maximum permitted distance.

2. General

The obstacles will be standard Show Jumping obstacles. There will be 10 to 13 in number, with 13 to 16 efforts maximum depending on the level of the event as per limits shown in Annex 4.

2010 RULES FOR EVENTING

3. Dimensions

The dimensions of the obstacles shall not exceed the limits shown in Annex 4. At least two thirds shall be of maximum height for the level offered. The top spread of an obstacle may not be more than the dimensions set in Annex 4. A tolerance of 5 cm in height is acceptable, if dictated by the terrain or by the spacing of the cups as authorized by the FEI Jumping Rules.

4. Type of Obstacles

The obstacles should have a balance of vertical and spread obstacles and shall include two or three doubles or a double and a treble.

Closed combinations are not permitted. A water jump is not permitted, but a water ditch with rails over is allowed. FEI approved safety cups ~~of 25mm~~ must be used as support for back poles of spread obstacles, and in the case of a triple bar, to support the centre and back pole of the obstacle. Alternative obstacles are permitted. These jumps are to be marked on the course plan with the same number and with the word "Alternative".

Article 538 SCORING

1. Faults on the Course

Knocking down an obstacle	4 penalties
First run-out, refusal or unauthorised circle in the whole test	4 penalties
Second run-out, refusal or unauthorised circle in the whole test	elimination
First fall of athlete or horse	elimination

2. Time Faults

The length of the course and the speed demanded determine the time allowed. Completing the course in less than the time allowed is not rewarded, but exceeding the time allowed is penalised by one penalty for each second or part of a second in excess of the time allowed, up to the time limit, which is twice the time allowed. Exceeding the time limit involves elimination.

Article 539 TIME CORRECTIONS

1. Knock-down with Disobedience

1.1 IF, as a result of a disobedience, an athlete displaces or knocks down an obstacle, the bell is rung. The clock is stopped until the obstacle has been rebuilt. The athlete will be penalised for a refusal and 6 seconds will be added to the time taken by the athlete to complete his test.

1.2 IF an athlete displaces or knocks down one of the elements of a combination and refuses or runs out at one of the subsequent elements,

2010 RULES FOR EVENTING

the bell is rung. The clock will be stopped as for an obstacle knocked down following a disobedience. The penalties for the disobedience and the addition of 6 seconds must be applied.

Chapter VI Games, Championships & Cups

Article 540 OLYMPIC GAMES

Every four years, Eventing in the Olympic Games will be organised under the patronage of the International Olympic Committee (IOC). The Olympic Three Day Event is for Seniors. It will be conducted at the Four Star level in accordance with the "Special Regulations for Equestrian Events at the Olympic Games".

Article 541 WORLD INDIVIDUAL & TEAM CHAMPIONSHIPS

1. Organisation

1.1 EVERY FOUR YEARS, in the even year between the Olympic Games, the World Individual and Team Eventing Championship will be organised under the authority of the FEI.

1.2 APPLICATIONS TO HOST the World Championship shall be directed to the FEI in accordance with the "General Regulations".

1.3 THE WORLD CHAMPIONSHIP is for Seniors. It will be conducted at the Four Star level, except as noted below. The Dressage test will be the most recent Four Star Dressage Test.

1.4 OFFICIALS will be appointed in accordance with Art. 550. Their expenses will be paid in accordance with the "General Regulations".

1.5 WORLD CHAMPIONSHIPS can only be held if at least six NFs are represented. As an exception to the "General Regulations", an NF that withdraws after the definite entries have been submitted, but before the First Horse Inspection, is considered as represented.

2. Invitations

Invitations shall automatically be sent to all NFs represented at Three and Four Star competitions during the previous two years. They will also be sent to any other NF upon request.

3. Qualifications

Athletes and horses must qualify as a combination at Three or Four Star competitions in accordance with Art. 506.7.2.

4. Participation

4.1 IF THE WORLD CHAMPIONSHIP is conducted as a separate competition, the number of athletes will be in accordance with Art. 503.2.3 for Championships. If Eventing is conducted at the same time as other World Championships, for example as part of the World Equestrian Games, then the host nation will be limited to the same number of athletes and horses as foreign countries.

4.2 AN ATHLETE may ride only one horse in a World Championship.

2010 RULES FOR EVENTING

5. Expenses & Privileges

The Organising Committee will be responsible for travelling, accommodation and living expenses of athletes, grooms, horses and additional officials in accordance with Art. 508.2 - Championships.

Article 542 WORLD CUPS FOR INDIVIDUALS

The FEI may authorise the organisation of World Cups for Individuals. The World Cup will be for Seniors. Separate Rules, qualification and participation must be approved by the FEI Eventing Committee.

Article 543 CONTINENTAL GAMES

In certain parts of the world, Eventing at Continental Games (such as the Asian Games and Pan American Games) may be organised under the patronage of the International Olympic Committee and Regional Games Associations. The particular regulations for these events must be approved by the Secretary General and by the Chairman of the Eventing Committee. In principle, they will be organised in accordance with Art.544- Continental Championships.

Article 544 CONTINENTAL INDIVIDUAL & TEAM CHAMPIONSHIPS

1. Organisation

1.1 CONTINENTAL INDIVIDUAL and Team Eventing Championships will be organised under the authority of the FEI as follows:

1. SENIORS - every two years, in the odd years between Olympic Games

2. YOUNG RIDERS - every year

3. JUNIORS - every year

1.2 APPLICATIONS to host these Championships shall be directed to the FEI in accordance with the "General Regulations".

1.3 THE LEVEL OF THE CHAMPIONSHIPS will be decided by the FEI after discussion with the relevant NFs.

1.4 OFFICIALS will be appointed in accordance with Art. 550. Their expenses will be paid in accordance with the "General Regulations".

1.5 CONTINENTAL CHAMPIONSHIPS for Seniors can only be held if at least three NFs and/or Regional Teams are represented at the First Horse Inspection.

1.6 REGIONAL REPRESENTATION at a Continental Championships – the territorial scope must be previously approved by the FEI.

1.7 CONTINENTAL CHAMPIONSHIPS for Young Riders and Juniors can be held in Europe only if at least three NFs are represented. Outside Europe, they may be held with any number of Regional Teams from at least two NFs. An NF that withdraws after the Definite Entries have been submitted, but before the First Horse Inspection, is considered as represented.

2010 RULES FOR EVENTING

1.8 THE COMPETITION RULES for Young Riders are held at the Two Star level as determined by the FEI Eventing Committee.

The competition rules for Juniors are held at the One Star level.

2. Invitations

In principle, Continental Championships are open only to athletes from NFs in the continent concerned. Invitations will automatically be sent to the NFs involved. However, with the approval of the FEI, and with the exception of Senior Championships in Europe, Organising Committees may invite NFs from outside the continent to send athletes.

An NF taking part in a Continental Championship outside its continent will not have the right to organise the following Championship should it be successful. However, it has the right to win the Individual or Team medals.

3. Qualifications

Athletes and horses must qualify in accordance with Art. 506, appropriate to the level of the Continental Championship.

4. Participation restrictions - Young Riders and Junior Championships

4.1 ATHLETES AND HORSES may only take part in either a Junior or a Young Rider or a Senior Championship in any calendar year.

4.2 THE PARTICIPATION of a Young Rider in a championship in one discipline for Young Riders does not exclude the same Athlete on another horse from participating in a championship for seniors in another discipline, if he has reached the appropriate age.

4.3 ONCE AN ATHLETE has taken part in a championship for Seniors or in a regional or Olympic Games in a particular discipline, he can no longer go back to a championship for Juniors in the same discipline.

4.4 IN THE EVENT of a championship being held at the same time or almost the same time, and at the same place of a Senior championship, CCI or CCIO, no horse may compete or be ridden by a Young Rider as well as by a Senior during these events.

5. Number of horses' per Athlete at a Championship

An athlete may ride only one horse in a Championship.

6. Expenses & Privileges

The expenses and privileges for athletes, horses and officials will be in accordance with the following articles: Art. 507.3. & 508.2

7. Young Rider & Junior Championships – Responsibility

The Chefs d'Equipe are responsible for the behaviour of their teams and/or individuals throughout the event. They and their NF are responsible for any damages that occur. If the Athletes are not lodged in private homes, the Chefs d'Equipe must stay with their teams and/or individuals.

The Appeal Committee has the authority to assess any costs for damages. According to the FEI legal system, the Appeal Committee may impose a fine

2010 RULES FOR EVENTING

and has the right to disqualify the team and/or individuals with unacceptable behaviour at any stage throughout the event.

8. Young Rider & Junior Championships – Medals & Prizes

The following minimum number of awards must be presented

8.1 TEAM CHAMPIONSHIP - FEI MEDALS (see "General Regulations", Art. 111.5). In addition, prize money to horse owners and/or prizes in kind, plaques and rosettes for each of the Athletes in the teams taking the first four places.

8.2 INDIVIDUAL CHAMPIONSHIP - FEI MEDALS (see "General Regulations", Art. 111.5). In addition, prize money and/or prizes in kind, plaques and rosettes at a rate of one prize for each commenced four Athletes with a minimum of five prizes.

8.3 THE PRIZE-GIVING CEREMONY should be given great importance and should be held in the arena with the Athletes mounted.

8.4 ALL CHEFS D'EQUIPE and Athletes should be presented with a souvenir or a plaque

8.5 ORGANISERS should award as many extra prizes as possible, e.g.: Athlete with the best style (possible division), best girl Athlete, best boy Athlete, Sportsmanship, Veterinary prize to the horse in the best condition.

Article 545 CONTINENTAL CUPS FOR INDIVIDUALS

The FEI may authorize the organisation of Continental Cups for Individuals. The regulations for organisation and participation must be approved by the FEI.

Article 546 REGIONAL GAMES

In certain parts of the world, Eventing at Regional Games (such as the Central American, Caribbean Games or the Mediterranean Games) may be organised under the patronage of the International Olympic Committee and Regional Games Associations. The particular regulations for these events must be approved by the FEI Eventing Committee. In principle, they will be organised in accordance with Art. 544 - Continental Championships.

Article 547 REGIONAL INDIVIDUAL & TEAM CHAMPIONSHIPS

In certain parts of the world, Regional Individual and Team Eventing Championships (such as Alps, Amazon, Balkan, Scandinavian, Tasman, Rural etc.) may be organised under the authority of the FEI in accordance with the "General Regulations", Art. 110.4. In principle, they will be organised in accordance with Art. 544 - Continental Championships. At least two countries must be represented at the First Horse Inspection.

Chapter VII Officials at International Events

Article 548 JURISDICTION OF OFFICIALS

The period of an event commences one hour before the beginning of the 1st Horse Inspection and terminates half an hour after the announcement of the final results (General Regulations).

However, the jurisdiction of the Ground Jury commences when they inspect and approve the cross country course, or at the First Horse Inspection, or one hour prior to the start of the dressage, whichever is earlier.

Article 549 DUTIES OF OFFICIALS

The Ground Jury, Technical Delegate(s), Course Designer and Veterinary Delegate, in conjunction with the OC, shall endeavour to ensure that all the arrangements for the event are fair, safe and appropriate. This shall include the arenas, courses, obstacles and footing.

1. Ground Jury

1.1 THE GROUND JURY is ultimately responsible for the judging of the event and for settling all problems that may arise during its jurisdiction. If, after consultation with the Technical Delegate, the Ground Jury is not satisfied with the arrangements or courses, it is authorised to modify them.

1.2 FOR CH/CCI 4/3* the Ground Jury shall consist of the President and two Members; for CH/CCI 2/1* & CICs the Ground Jury shall consist of the President and one or two members.

1.3 THE PRESIDENT and members of the Ground Jury will be chosen from the appropriate lists of Eventing Judges in accordance with Art. 550.

1.4 AT ALL EVENTS, the Ground Jury will conduct the First and Second Horse Inspections with the Veterinary Delegate.

1.5 THE GROUND JURY will judge the Dressage Test.

1.6 INSPECTION OF THE CROSS COUNTRY and Jumping Courses. The Ground Jury inspects and approves the cross country and jumping courses with the Technical Delegate and Course Designer.

1.7 CROSS COUNTRY TEST

1. CROSS COUNTRY CONTROL. Either the President of the Ground Jury must be in cross country control or if the President of the Ground Jury does not speak or understand the language which is being used for communication purposes, one of the members of the Ground Jury who does speak and understand the language must be there instead. The President shall make this decision.

2. ON COURSE. One Member of the Ground Jury must be on the Cross Country course with the usual responsibilities.

3. FOR CCIS the 3rd Member of the Ground Jury (if there is one) must be at the start/finish area fulfilling the usual role. If the start and finish are in separate locations he/she should be at the start.

2010 RULES FOR EVENTING

4. FOR CICS the 3rd Member of the Ground Jury (if there is one) may also be on the cross country course but must be available to go to the finish at short notice should the Veterinary Delegate at the end of the Cross country course need his/her opinion.

5. AT ALL INTERNATIONAL EVENTS, the President and the Members of the Ground Jury shall retain the same task throughout the Cross Country event.

1.8 THE GROUND JURY will be responsible for determining objections against decisions by technical personnel, including fence judges and timekeepers, on the Cross-Country Test and may substitute their judgement for that of any judge or official, whether in favour of the athlete or not.

1.9 THE GROUND JURY will be responsible for the judging of the Jumping Test.

1.10 IT IS ESSENTIAL that the President of the Ground Jury or appointed Jumping Judge be in control of the bell. At CICs, if the Jumping takes place while other phases are also happening, this task may be delegated to a qualified national or international Jumping Judge. At all events at 3 or 4 star level and at all Games and Championships the Ground Jury must be assisted by a qualified and experienced jumping judge while at all other events such assistance is recommended. Should any member of the Ground Jury be also a qualified Jumping Judge, no additional member is required.

1.11 ANY MEMBER of the Ground Jury shall have the duty and full authority at any time during the event to eliminate from the event any horse that is lame, sick or exhausted and any athlete that is unfit to continue and to take action in cases of dangerous riding. See Art 519. There is no appeal against such a decision.

2. Technical Delegate

2.1 THE TECHNICAL DELEGATE will approve the technical and administrative arrangements for the conduct of the event, for the examinations and inspections of horses, for the accommodation of horses and athletes and for the stewarding of the event.

2.2 FOR ALL THREE TESTS, the Technical Delegate will inspect and approve the courses, arenas and facilities for exercising and training, including the type and dimensions of the obstacles and measurements of all courses, with particular reference to their suitability for the level of the event. Technical Delegates are specifically required to measure all courses to ensure they are of the indicated distances. He must be able to inspect early enough to allow for modifications to be made. He may request one or more horses to try out any part of the arenas or tracks.

2.3 HE WILL supervise the briefing and conduct of all technical personnel.

2.4 HE WILL investigate all enquiries regarding scoring, including penalties awarded, and report to and advise the Ground Jury on any decisions they are required to make.

2.5 UNTIL HE HAS REPORTED to the Ground Jury that he is satisfied with all the arrangements, the authority of the Technical Delegate shall be absolute. Thereafter, he will continue to supervise the technical and

2010 RULES FOR EVENTING

administrative conduct of the event and will advise and assist the Ground Jury, Veterinary Commission and the Organising Committee.

2.6 THE TECHNICAL DELEGATE has the authority to warn or stop an athlete on Cross Country course for dangerous riding, riding an exhausted horse, excessive pressing of a tired horse, riding an obviously lame horse, excessive use of whip and/or spurs or riding in an unsafe way. Also refer to Art. 519.

2.7 THE TECHNICAL DELEGATE is responsible for reporting back accordingly after the events to FEI Headquarters

3. Course Designer

3.1 THE COURSE DESIGNER is responsible for the layout, measurement, preparation and marking of the route for the Cross-Country.

3.2 HE is responsible for the design, construction and marking of the obstacles on Cross Country.

3.3 THE EVENTING COURSE DESIGNER is responsible for the layout, design and construction of the Jumping course and he/she must ensure that the course complies with all the current Eventing rules and guidelines.

For One and two Star events, a nationally recognised Jumping Course Designer is recommended. The duty of building the Jumping course will be delegated to a national Jumping Course Designer for Two & Three Star events and One & Two Star Championships. For Four Star events and Four/Three Star Championships, they must be delegated to a FEI "International" Jumping Course Designer.

4. Veterinary Commission

4.1 APPOINTMENT/RESPONSIBILITIES

1. AT GAMES, CHAMPIONSHIPS, CUP FINALS, CCIOS AND CCIS, the Veterinary Commission, shall consist of two veterinarians, the Veterinary Delegate and the Associate Veterinarian. They will be jointly responsible for approving the veterinary arrangements for the event and individually responsible for the specific duties set out below.

At major Games &/or multi-disciplinary Championships, the FEI may decide to appoint in addition a President of the Veterinary Commission, who will take responsibility for liaison with the OC for the prior arrangements.

2. AT CCI 2/1* & CICS the Veterinary Commission may consist of only the Veterinary Delegate. In such a case, there must be an Examining Veterinarian with the appropriate experience to officiate in the Holding Box at the First and ~~Third~~ **Second** Inspections (see Veterinary Regulations Art 1003.8).

4.2 VETERINARY DELEGATE

1. TOGETHER with the Associate Veterinarian, he will be responsible for the First Examination of Horses.

2. HE WILL REVIEW with the Appeal Committee any passport irregularities and make any necessary recommendations on appropriate penalties.

3. HE WILL BE A MEMBER of the Committee for the First and Second Horse Inspections.

4. HE WILL SUPERVISE the Control of Medication.

2010 RULES FOR EVENTING

5. HE WILL BE RESPONSIBLE for authorising access to the stables for team or individual athletes' own veterinarians.

6. THE VETERINARY DELEGATE will liaise with Treating Veterinarians for their whereabouts and availability on the Cross Country course at all times. Radio contact is essential.

4.3 ASSOCIATE VETERINARIAN

1. TOGETHER with the Veterinary Delegate, he will be responsible for the First Examination of Horses.

2. HE WILL ASSIST in the holding area at the Horse Inspections, examining horses and reporting his findings to the Ground Jury and the Veterinary Delegate.

3. HE WILL SUPERVISE the veterinary services during the event, including the emergency arrangements during Cross-Country.

5. Appeal Committee

5.1 THE DUTIES of the Appeal Committee are as laid down in the "General Regulations" and in the "Veterinary Regulations".

5.2 FULL APPEAL COMMITTEES (a President & at least 2 Members) are compulsory for Eventing Championships and World Cup Finals. It must consist of a foreign member – see GR Art 150.

5.3 AT ALL OTHER INTERNATIONAL EVENTS, the duties of the Appeal Committee may, at the OC's discretion be carried out by the Ground Jury.

5.4 EXCEPT AT A CHAMPIONSHIP, an Appeal Committee, if appointed, may consist of a single person, who must in such a case be an Official International or International Judge or an International Technical Delegate, who is not officiating in the competition in any other capacity.

6. Stewards

The duties of the stewarding team are to assist the OC, the Ground Jury, Technical Delegate and athletes in the conduct of the event according to the Rules, paying due respect to the guidelines defined in the Code of Conduct for Welfare of the Horse. Specifically, but not exclusively, their duties cover planning and supervision of work in all exercise, practice, warm-up, and stable areas, checking of dress and saddlery, assistance with Horse examinations and Inspections. They are expected to work closely with the OC, athletes, TDs and other Officials.

7. Conflict of Interest

All levels of Eventing Championships: for all categories of FEI Officials (Judges/Technical Delegates/Course Designers/Veterinarians) no conflict of interest is allowed – e.g. close relative to a athlete or owner, trainer or coach to a horse or athlete.

For all FEI Officials, Course walks open to all athletes are encouraged, but those restricted to own pupils are not allowed.

Note: Coaching includes the walking of courses, the training & warming up of athletes for dressage or jumping on the flat.

7.1 FOR ALL FEI CHAMPIONSHIPS/TEAM EVENTS & WORLD CUP FINALS:

Judges: conflict of interest is not allowed

2010 RULES FOR EVENTING

Technical Delegates: Independent Panel to review the case and to decide if the conflict is acceptable. In all cases, if the TD has a Conflict of Interest, the Assistant TD is empowered to act in his place. For all CH & 4/3* events an Assistant TD is appointed.

Course Designers: Independent Panel to review the case and to decide if the conflict is acceptable.

7.2 FOUR AND THREE STAR EVENTS:

Judges: Independent Panel to review the case and to decide if the conflict is acceptable.

Technical Delegates: Independent Panel to review the case and to decide if the conflict is acceptable. In all cases, if the TD has a conflict of Interest, the Assistant TD is empowered to act in his place. For all Championships & 4/3* events an Assistant TD is appointed.

Course Designers: Independent Panel to review the case and to decide if the conflict is acceptable.

7.3 TWO AND ONE STAR EVENTS

Judges/Technical Delegates/Course Designers: As of arrival on the competition grounds, Officials cannot have any conflict of interest as per above. Special consideration may be given, providing the conflict is declared in advance to the FEI Secretary General who may allow it in his discretion.

Coaching or training must be avoided after arriving at the competition grounds, unless in special circumstances permission has been given by the FEI Secretary General.

7.4 INDEPENDENT REVIEW PANEL

Unresolved issues for Championships and events relating to conflict of Interest may be referred to a panel consisting of three members. The FEI Secretary General shall appoint this panel in the beginning of each year to be composed of two sportsmen (recent retired athletes) and one Member with legal knowledge (as well as a reserve member). This panel may confer by email or telephone. In emergency any one member of the panel may make a decision.

Article 550 APPOINTMENT OF OFFICIALS

1. Games, Championships, Cup Finals

1.1 IN CASE OF 4* & 3* GAMES, CHAMPIONSHIPS OR CUP FINALS, the Judges, Foreign Technical Delegate, Veterinary Commission, will be appointed by the FEI after consultation with the OC. All Officials must be selected from the International lists of Officials. International Ground Juries are compulsory.

1.2 IN CASE OF 2* & 1* GAMES, CHAMPIONSHIPS, the President of the Ground Jury, Foreign Technical Delegate and Foreign Veterinary Delegate will be appointed by the FEI after consultation with the OC. International Ground Juries are compulsory. The OC has the option of inviting one or two members for the Ground Jury. Course Designers must be selected from the International lists of Officials.

2010 RULES FOR EVENTING

Championships

Championships, Games, World Cup Final	4 Star	3 Star	2 Star	1 Star
Ground Jury Appointed by FEI with consultation NF/OC	3 Judges	3 Judges	Option of 2 or 3 Members	Option of 2 or 3 Members
	All GJ Members must be chosen from FEI "I" list			
	International Ground Jury Compulsory			
Foreign Technical Delegate	Must be chosen from FEI "I" list			
	Jumping Judge Compulsory			
Course Designer	CD must be chosen from FEI "I" list			
Jumping Course Designer	FEI Jumping "I" list	FEI Jumping "I" list	Minimum national listed Jumping Course Designer	
Veterinary Commission	Foreign Vet Delegate and Associate Vet from FEI list			
Appeal Committee	President & 2 Members (one Foreign & Eventing Official & Legal Knowledge)			
Chief Steward	From FEI Eventing list			

2. Three Day Events (CCIs)

Judges, Technical Delegates and Course Designers for all international Three Day Events will be appointed in accordance with the table below.

CCI (3DE)	4 Star	3 Star	2 Star	1 Star
Ground Jury	3 Judges		Option of 2 or 3 Members	
	All GJ Members must be chosen from FEI lists		1 GJ member must be chosen from FEI lists	Can be national Judges if TD on FEI lists
	Three "I" or "O" judges compulsory	One "I" or "O" Judge compulsory		Either a Member of the GJ or TD to be chosen from FEI lists
	Foreign Member of GJ compulsory		Foreign Official compulsory	
	Jumping Judge compulsory		n/a	
Technical Delegate				Either Member of the GJ or TD to be chosen from FEI lists

2010 RULES FOR EVENTING

	TD must be chosen from FEI "I" list	CD & TD to be chosen from FEI lists	TD may be national if a Member of GJ from FEI lists
Course Designer	CD must be chosen from FEI "I" list	CD & TD to be chosen from FEI lists	CD may be national
Jumping Course Designer	"I" Jumping CD	National Jumping Course Designer	Nationally recognised Jumping Course Designer recommended
Veterinary Officials	2 Vets: Vet Delegate and Associate Vet from FEI list		
Appeal Committee	Full Appeal Committee or 1 Member or Ground Jury		
Chief Steward	Must be chosen from FEI Eventing list	Can be national Steward	

3. CIC Events

CIC	3 Star	2 Star	1 Star
Ground Jury	2 or 3 Members	2 or 3 Members	2 or 3 Members
	Either Foreign TD or Foreign Member of GJ compulsory		
	All GJ Members must be chosen from FEI lists	At least one GJ member must be chosen from FEI lists	Either Member of the GJ or TD to be chosen from FEI lists
	One "I" or "O" Judge compulsory		Can be national Judges if TD on FEI list
	Jumping Judge compulsory	n/a	
Technical Delegate	TD must be chosen from FEI "I" list	TD must be chosen from FEI lists	Either Member of the GJ or TD to be chosen from FEI list
	Either Foreign TD or Foreign Member of GJ compulsory	Foreign requirement not compulsory, however one member of GJ, TD or CD must be from "I" list	TD may be national if a Member of GJ from FEI list
Course Designer	Must be chosen from FEI lists	Can be National CD	

2010 RULES FOR EVENTING

Jumping Course Designer	National Jumping Course Designer	Nationally recognised Jumping Course Designer recommended
(Exceptional Case) AUS & NZL only for cost reasons	Foreign official not compulsory, however 2 GJ members, TD and CD must be from "I" lists	n/a
Veterinary	1 Vet Delegate from FEI list & a holding box Vet	
Chief Steward	Must be chosen from FEI lists	Can be national Steward

1. The FEI Judge ("I" or "C") must be appointed as President of the Ground Jury if there is a national Judge as second Judge.
2. If there is an "I" Judge appointed for an event, he should be recommended as President over the "C" Judge.

4. Veterinarians

4.1 VETERINARIANS FOR EVENTING AT GAMES, Championships or Cup Finals must be selected from the list of Contact Veterinarians and Event Veterinarians who have experience in Eventing. The appointments must be in accordance with the "General Regulations" and the "Veterinary Regulations".

4.2 VETERINARIANS FOR ANY OTHER INTERNATIONAL THREE DAY EVENT at any level must be selected from the list of Contact Veterinarians and Event Veterinarians who have experience in Eventing. The veterinarians may be from the host country. They will be appointed by the Organising Committee and the National Federation.

5. Appeal Committee

The appointment of the President and members of the Appeal Committee must be in accordance with the "General Regulations".

6. Stewards

6.1 AT ALL INTERNATIONAL EVENTS a Chief Steward must be appointed.

6.2 AT CHAMPIONSHIPS, CCIOS, CCI 4/3* AND CIC 3* he/she must be selected from the FEI lists for Eventing.

6.3 AT CCI/CIC 2/1* the Chief Steward may be a suitably qualified national official. Other Stewards, under the management of the Chief Steward, must be appointed as appropriate to the category and level of Event, and to its particular layout and characteristics.

7. Appointment Restrictions

7.1 GROUND JURY: The same combination of members of a Ground Jury may not be appointed by an OC for two consecutive years.

No judge may serve as a member of a Ground Jury at more than 5 International Three Day Events (CH, CCIO, CCI) in any calendar year.

2010 RULES FOR EVENTING

7.2 TECHNICAL DELEGATES: No Technical Delegate may officiate at more than 5 International Three Day Events in any calendar year.

No Technical Delegate may officiate at one event for more than 3 consecutive years

8. Assistant Technical Delegate

An assistant Technical Delegate must be appointed by the OC for all Games, Championships, Cup Finals, CCIOs and Four & Three Star events (CCI and CIC) and may be appointed at other international events.

The assistant TD may be selected from the FEI lists or may be a national TD. At Games, Championships, Cup Finals and all Four Star events the assistant TD must be of a different nationality to the TD.

9. Number of TDs per event

One TD can officiate at maximum 2 categories/**star levels** per event. If one or two additional categories/**levels** are included, **and when the number of entries in the overall event exceeds 100 horses**, 1 additional TD must be appointed **and 2 additional TDs are required** should 5 categories be organised at the same event. ~~2 additional TDs must be appointed.~~ The status of additional TDs can be national.

10. Course Designer

The Course Designer must be present for the Cross Country Course Inspection with the Ground Jury for the event's Cross-Country test he is responsible for. If for any serious reason, the appointed Course Designer cannot be present also during the Cross Country test, a qualified CD of at least "Candidate" status, familiar with the course, can be appointed to replace him/her. Any infringement of this article will be reported to the FEI Secretary General for action to be considered by the FEI Tribunal.

Article 551 JUDGES

1. Categories of Judges

International Judges are divided into three categories:

1. Candidate Judges
2. International Judges
3. Official International Judges

2. Qualifications of Judges

2.1 CANDIDATE JUDGE - The qualifications of a Candidate Judge are as follows:

1. To have regular practice as a National Judge over a period of at least two years, including acting as the President or a member of the Ground Jury at a minimum of two CICs conducted under FEI Rules or two International Events (CCI 2/1*/CIC) of which at least one must be a CCI.
2. To have successfully completed an FEI approved course for Candidate Judges, including demonstration of sufficient knowledge of the rules and

2010 RULES FOR EVENTING

conduct of Eventing and a satisfactory ability to judge dressage and jumping, and be recommended for promotion by the Course Director.

3. To be not more than 70 years of age
4. To understand English, the official language.
5. To be listed as a National Approved Dressage Judge in own country.
6. To be familiar with and to fully understand the "Training Scale" as per the Rules for Dressage.

All requirements must be clearly documented by the NF responsible and be submitted to the FEI with the application to become a Candidate Judge.

2.2 INTERNATIONAL JUDGE - The qualifications of an International Judge are as follows:

1. To have judged regularly at both national and international competitions with a minimum of four International Events (CCI/CIC) during the current or preceding two years.
2. To have completed successfully an FEI approved course for International Judges within the past three years and to be recommended for promotion and/or continuation on the list by the Course Director.
3. To understand and speak English.
4. To be not more than 70 years of age.
5. To have gained experience in judging on Medium level Dressage Tests including collection in walk, trot and canter; single changes; half-passes and shoulder-in. If it can be documented by the National Federation that a national Eventing officials programme is on the same level and standard as mentioned above, this will also be regarded as fulfilling experiences and education.
6. To have officiated as a Shadow Judge, at least 3 times, at National/International 3 Star Eventing events or at Dressage National/International competitions of at least FEI Prix St.-George Level.
7. Or alternatively, to have currently judged, at least 3 times, at National/International 3 Star level Eventing events or at Dressage competitions of at least FEI Prix St-George level (National/International).

All requirements must be clearly documented by the NF responsible and be submitted to the FEI with the application to become an International Judge.

2.3 OFFICIAL INTERNATIONAL JUDGE - The qualifications of an Official International Judge are as follows:

1. To fulfil and to continue to fulfil the qualifications of an International Judge.
2. To have had considerable experience proven by excellent performance as president or member of Ground Juries at major FEI events.
3. To be not more than 70 years of age.

3. Promotion of Judges

3.1 CANDIDATE JUDGE - The FEI maintains a list of qualified Candidate Judges who have been recommended by their NF and who have been accepted by the Eventing Committee. They must meet the qualifications of a Candidate Judge before they may be recommended by their NF.

3.2 INTERNATIONAL JUDGE - The FEI maintains a list of qualified International Judges who have been appointed by the Eventing Committee after consultation with the relevant NFs. They must meet the qualifications of an International Judge before they may be appointed.

2010 RULES FOR EVENTING

3.3 OFFICIAL INTERNATIONAL JUDGE - The FEI maintains a list of Official International Judges who were formerly selected by the Eventing Committee from the list of International Judges and approved by the Bureau. No further Official International Judges will be appointed.

4. Fulfilment of Requirements

4.1 CANDIDATE JUDGES who do not meet the requirements for Candidate Judges will be dropped from the FEI Judges list.

Candidate Judges who do not meet the requirements for an International Judge may continue on the Candidate Judges list at the discretion of the Eventing Committee, provided they continue to fulfil the requirements of a Candidate Judge.

4.2 INTERNATIONAL JUDGES or Official Judges who do not meet the requirements for an International Judge may be moved to the Candidate Judges list or dropped from the list, at the discretion of the Eventing Committee.

Article 552 TECHNICAL DELEGATES

1. Categories of Technical Delegates

International Technical Delegates are divided into two categories:

1. Candidate Technical Delegates
2. International Technical Delegates

2. Qualifications of Technical Delegates

2.1 CANDIDATE TECHNICAL DELEGATE - The qualifications of a Candidate Technical Delegate are as follows:

1. To have regular practice as a National Technical Delegate over a period of at least three years, including acting as Technical Delegate at a minimum of two CCIs 2/1*, CCNs or CICs/CNCs conducted under the FEI Rules. They are encouraged to gain experience at all levels of CIC Events, as well as Three Day Events (CCN). Specifically, this experience should include work on Organising Committees and with a Course Designer, as well as experience as a Technical Delegate. This requirement may be reduced if the Technical Delegate is an International Judge or International Course Designer.
2. To have served as an assistant to an International Technical Delegate at a CCI.
3. To have successfully completed an FEI approved course for Candidate Technical Delegates, including demonstration of sufficient knowledge of the rules and conduct of Eventing, the "General Regulations", and the standards of the various levels of Eventing.
4. To be not more than 70 years of age
5. To understand English, the official language.

2.2 INTERNATIONAL TECHNICAL DELEGATE - The qualifications of an International Technical Delegate are as follows:

1. To have acted as a Technical Delegate at two International Events of which at least one must be a CCI during the current or preceding year.

2010 RULES FOR EVENTING

2. To have successfully completed an FEI approved course for Technical Delegates within the past three years and to have been recommended for promotion and/or continuation on the list by the Course Director.
3. To understand and speak English.
4. To be not more than 70 years of age.

3. Promotion of Technical Delegates

3.1 CANDIDATE TECHNICAL DELEGATE - The FEI maintains a list of qualified Candidate Technical Delegates who have been recommended by their NF and who have been accepted by the Eventing Committee. They must meet the qualifications of a Candidate Technical Delegate before they may be recommended by their NF.

3.2 INTERNATIONAL TECHNICAL DELEGATE - The FEI maintains a list of qualified International Technical Delegates who have been appointed by the Eventing Committee after consultation with the relevant NFs. They must meet the qualifications of an International Technical Delegate before they may be appointed.

4. Fulfilment of Requirements

4.1 CANDIDATE TECHNICAL DELEGATES who do not meet the requirements for Candidate Technical Delegate will be dropped from the FEI Technical Delegate list.

Candidate Technical Delegates who do not meet the requirements for an International Technical Delegate may continue on the Candidates list at the discretion of the Eventing Committee.

4.2 INTERNATIONAL TECHNICAL DELEGATES who do not continue to meet the requirements for an International Technical Delegate may either be moved to the Candidates list or dropped from the lists, at the discretion of the Eventing Committee.

Article 553 COURSE DESIGNERS - EVENTING

1. Categories of Course Designers

International Course Designers are divided into two categories:

1. Candidate Course Designers
2. International Course Designers

2. Qualifications of Course Designers

2.1 CANDIDATE COURSE DESIGNER - The qualifications of a Candidate Course Designer are as follows:

1. To have regular practice as a National Course Designer over a period of at least three years. They are encouraged to gain experience at all levels of CIC Events, as well as at Three Day Events. This requirement may be reduced if the Course Designer has experience as an international athlete.
2. To have successfully completed an FEI approved course for Candidate Course Designers, including demonstration of sufficient knowledge of the Rules for Eventing and the standards of the various levels, within the past four years.

2010 RULES FOR EVENTING

3. To be not more than 70 years of age.
4. To understand English the official language.

2.2 INTERNATIONAL COURSE DESIGNER - The qualifications of an International Course Designer are as follows:

1. To have regular practice as an International or Candidate Course Designer at CCIs and/or CICs and/or CCNs.
2. To have successfully completed an FEI approved course for International Course Designers within the past three years and be recommended for promotion and/or continuation on the list by the Course Director.
3. To understand, and preferably to speak English.
4. To be not more than 70 years of age.

3. Promotion of Course Designers

3.1 CANDIDATE COURSE DESIGNER - The FEI maintains a list of qualified Candidate Course Designers who have been recommended by their NF and who have been accepted by the Eventing Committee. They must meet the qualifications of a Candidate Course Designer before they may be recommended by their NF.

3.2 INTERNATIONAL COURSE DESIGNER - The FEI maintains a list of qualified International Course Designers who have been appointed by the Eventing Committee after consultation with the relevant NFs. They must meet the qualifications of an International Course Designer before they may be appointed.

4. Fulfilment of Requirements

4.1 CANDIDATE COURSE DESIGNERS who do not meet the requirements of Candidate Course Designers will be dropped from the FEI Course Designer List.

Candidate Course Designers who do not meet the requirements of International Course Designers may continue on the Candidates List at the discretion of the Eventing Committee provided they continue to fulfil the requirements of a Candidate.

4.2 INTERNATIONAL COURSE DESIGNERS who do not continue to fulfil the requirements of an International Course Designer may either be moved to the Candidates list or dropped from the list, at the discretion of the Eventing Committee.

4.3 THERE will be no Official International Course Designer's category for Eventing.

ANNEX 1a

Permitted Bits for the Dressage Test
Captions to plate showing permitted bits

VARIOUS BRIDOOON BITS

1. Ordinary bridoon bit
2. Bridoon bit with two joints
3. Egg-butt bridoon bit
4. Bridoon bit with cheeks or drop + cheek bridoon

VARIOUS TYPES OF CURB BITS

5. Half moon curb bit
6. Curb bit with straight cheeks and port
7. Curb bit with straight cheeks and port
8. Curb bit with port and sliding mouthpiece (Weymouth)
9. Variation of bits No 6+7
10. Curb bit with S-curved cheeks
11. Curb chain
12. Lip strap
13. Leather cover curb chain
14. Rubber cover for curb chain

2010 RULES FOR EVENTING

Drawings permitted bits

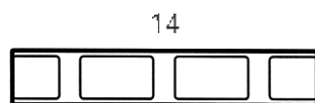
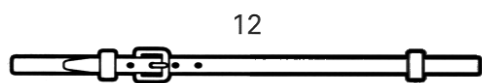
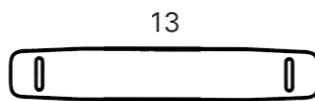
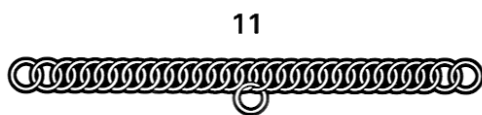
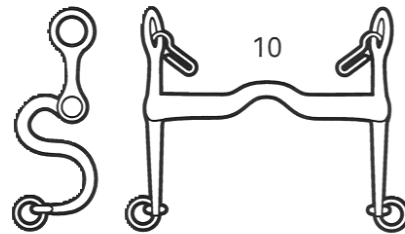
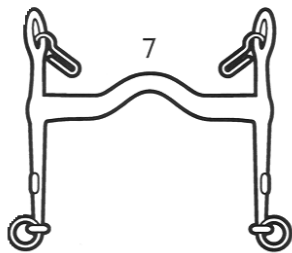
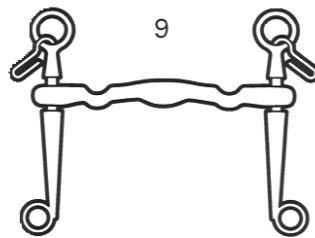
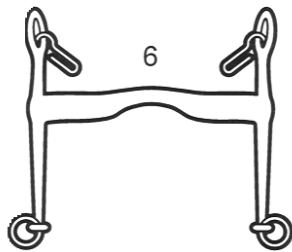
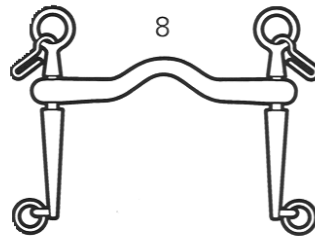
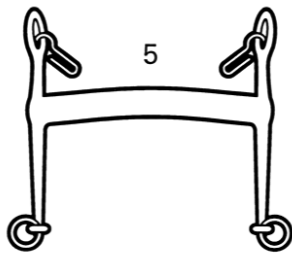
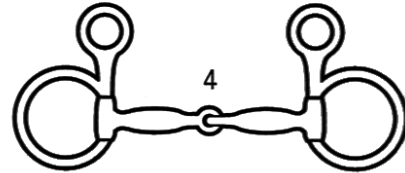
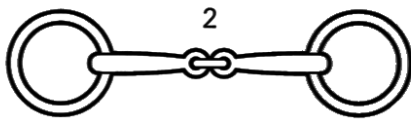
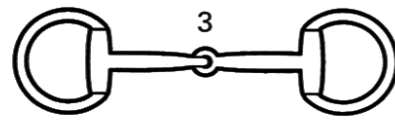
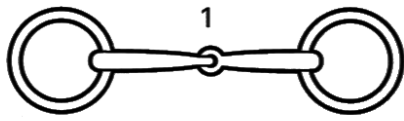

2010 RULES FOR EVENTING

Note: all bridoon bits shown on the plate of permitted bits in both the "Rules for Eventing" and the "Rules for Dressage Events" are permitted for the Dressage Test of Eventing either as a snaffle or as part of a double bridle. A double bridle should always consist of a broken (simple or double) and a straight bit. Bits can be made out of plastic or metal.

Any of the rings or cheeks shown on this plate are permitted with any of the bits.

An ordinary snaffle is a plain snaffle with a straight bar or joint in the centre.

If a snaffle has two joints, all parts must be rounded and smooth.

In addition, the following types of snaffle are permitted:

1. Ordinary snaffle with double jointed mouthpiece
2. Ordinary snaffle with jointed mouthpiece
3. Racing snaffle - "D Ring"
4. Egg butt snaffle:
5. with cheeks
6. without cheeks
7. Other type of snaffle with cheeks
8. Snaffle with upper cheeks only
9. Rubber, leather, rigid plastic or steel snaffle jointed or unjointed
10. Hanging cheek snaffle
11. Ordinary snaffle with double-jointed mouthpiece with lozenge
12. Ordinary snaffle with double-jointed mouth piece (French link)
13. Unjointed wavy rigid plastic or rubber snaffle (not steel):
14. with cheeks
15. without cheeks.
16. Ordinary snaffle with rotating mouthpiece
17. Snaffle with rotating middle piece

2010 RULES FOR EVENTING

Drawings - permitted snaffles

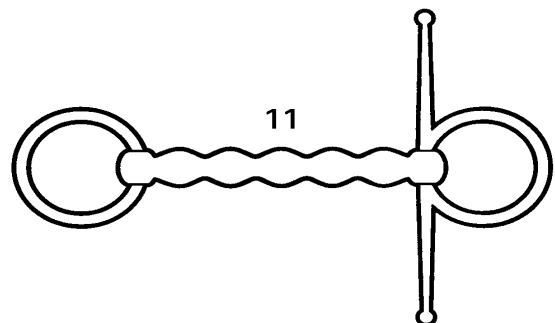
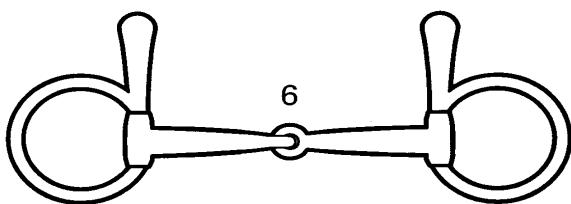
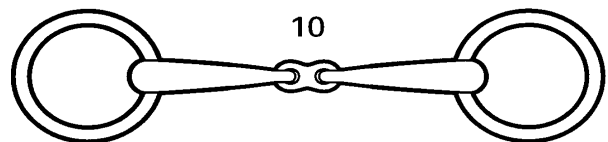
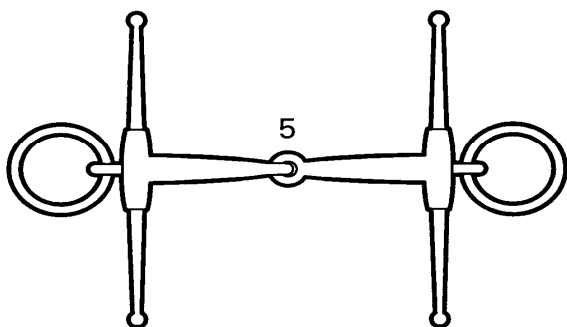
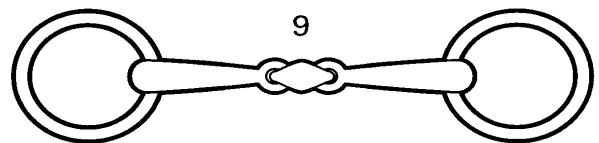
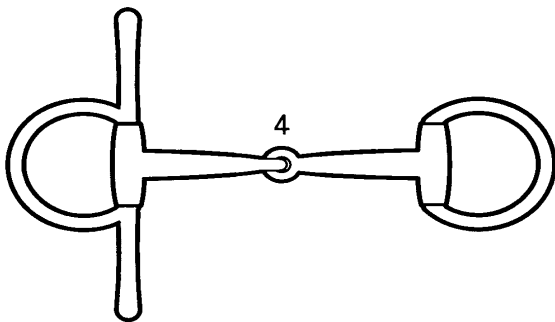
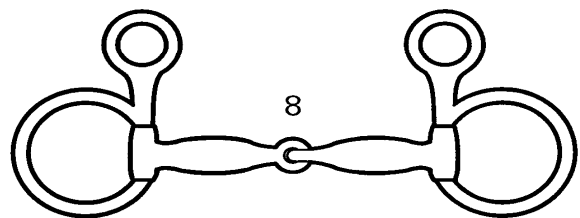
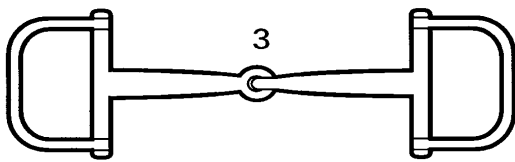
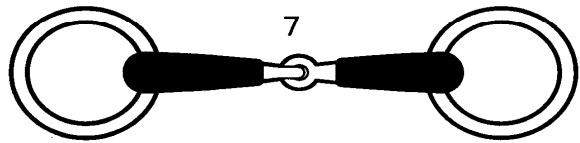
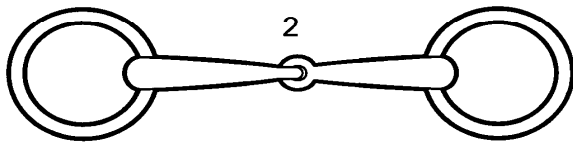
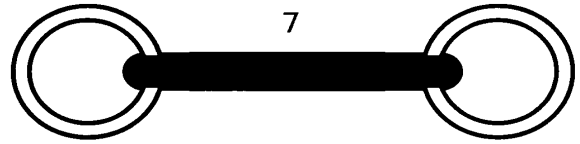
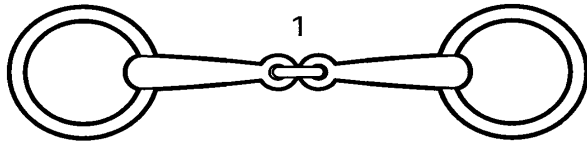

ANNEX 1b

Permitted Nosebands for the Dressage Test

1) Cavesson

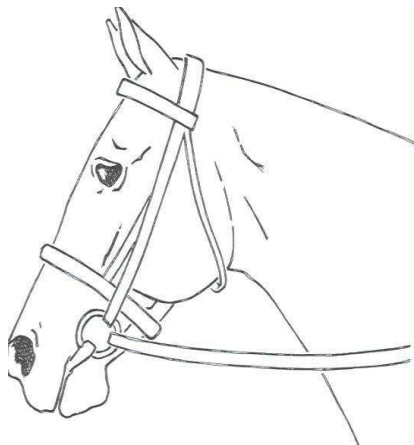

2) Crossed noseband

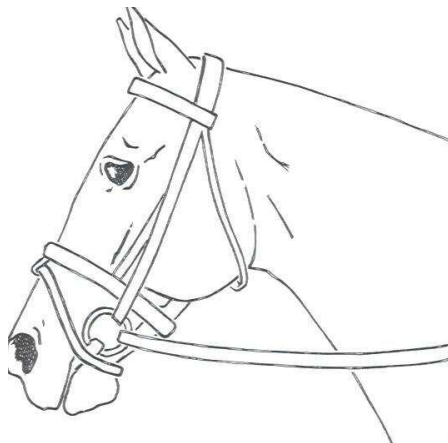
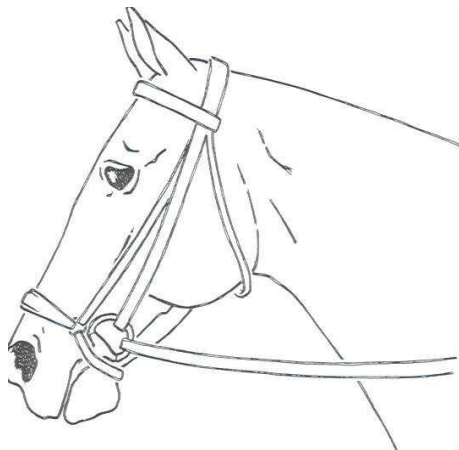
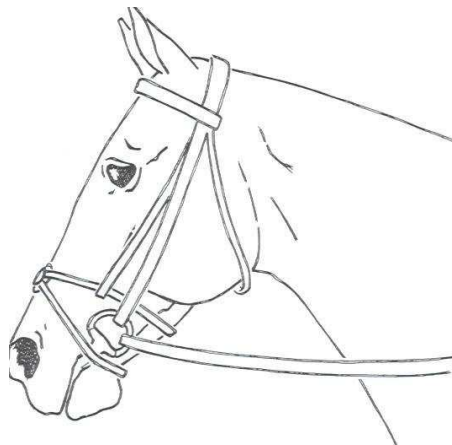

3

3) Dropped noseband

4) Flash noseband

2, 3 and 4 are not permitted when a double bridle is used

2010 RULES FOR EVENTING

ANNEX 2

Dressage Tests For Eventing

ONE Star Events (1*) CH/CCI/CIC	2009 A 1* test	approx 4 min	Annex 2.1
	2009 B 1* test	approx 5 min	Annex 2.2
TWO Star (2*) Events CH/CCI/CIC	2009 A 2* test	approx 5 min	Annex 2.3
	2009 B 2* test	approx 5 min	Annex 2.4
THREE Star (3*) Events CH/CCI/CIC	2009 A 3* test	approx 5 min	Annex 2.5
	2009 B 3* test	approx 5 min	Annex 2.6
FOUR Star (4*) Events CH/CCI	2009 A 4* test	approx 5 ¼ min	Annex 2.7
	2009 B 4* test	approx 5 ¼ min	Annex 2.8

Tests of each star level are used for CCIs or CICs.

Within the limits shown in Annex 4, Organising Committees are free to select the specific test to be used.

At Games, Championships and Cup Finals the dressage test to be used will be decided by the FEI.

- A Dressage tests would apply for all championships all **star** levels in uneven years.
- B Dressage tests would apply for all championships of all star levels in even years

2010 RULES FOR EVENTING

ANNEX 3a

Table of CCI Cross-Country Obstacle heights & Spreads/ Table of Speeds, Times, Distances & Maximum Jumping Efforts

CCI Cross Country	Four Star (4*)	Three Star (3*)	Two Star (2*)	One Star (1*)
Fixed	1.20 m	1.20 m	1.15 m	1.10 m
Brush	1.45 m	1.40 m	1.35 m	1.30 m
Max Spreads				
Highest Point	2.00 m	1.80 m	1.60 m	1.40 m
Base	3.00 m	2.70 m	2.40 m	2.10 m
Without height	4.00 m	3.60 m	3.20 m	2.80 m
Max Drops	2.00 m	2.00 m	1.80 m	1.60 m

ANNEX 3b

CCI / CIC Table of Speeds, times, distances & maximum Jumping Efforts

CCI CROSS COUNTRY	Four Star (4*)	Three Star (3*)	Two Star (2*)	One Star (1*)
Distance	6270-6840 m	5700-6270 m	4400-5500m 4950-5500m	4160-4680m
Speed	570 mpm	570 mpm	550 mpm	520 mpm
Time	11-12 min	10-11 min	8 9-10 min	8-9 min
Jump. Efforts	Max 42-45	Max 40	Max 37	Max 32
Alternative				
Distance	5700-6270m	5130-5700 m	4400-4950 m	3640-4160m
Time	10-11 min	9-10 min	8-9 min	7-8 min
Jump. Efforts	Max 42-43	Max 38	Max 35	Max 30

2010 RULES FOR EVENTING

CIC Cross-Country	Three Star (3*)	Two Star (2*)	One Star (1*)
Distance	3200-4000 m	2800-3600 m	2400-3200 m
Speed	570 mpm	550 mpm	520 mpm
Time	5mn30s-7 min	5mn-6mn30s	4mn30s-6 mn
Jump. Efforts	Max 40 36	Max 36 32	Max 32 29

As a guideline, for CICs, the ratio of efforts is

3 Star level = max. 1 effort per every commenced 110 meters (~~to be gradually enforced until 2010~~).

2 Star level = max 105 meters

1 Star level = max 100 meters

2010 RULES FOR EVENTING

ANNEX 4

Table of Jumping Obstacle Heights & Spreads / Distances, Speeds & Maximum Jumping Efforts

JUMPING Championships, CCI's & CICs	Four Star (4*)	Three Star (3*)	Two Star (2*)	One Star (1*)
OBSTACLES				
Heights:	1.25 m	1.25 m	1.20 m	1.15 m
Overall Spreads:				
Oxers	1.45 m	1.45 m	1.40 m	1.35 m
Triple Bar	1.65 m	1.65 m	1.60 m	1.55 m
Distance	Max 600 m	Max 600 m	Max 600 m	Max 600 m
Speed	375 mpm Ω	375 mpm Ω	350 mpm Ω	350 mpm Ω
NB Obst/ Max Efforts	11-13/16	11-12/15	10-11/14	10-11/13

Ω Size of the Arena (see Art 536 above) - If the arena is less than 5000 square meters, the maximum speed for Three and Four Star events shall be 350 meters/min

In arenas less than 2300 square meters the maximum speed for any level shall be 325/min

ANNEX 5

Diagram of Cross Country Obstacles & Faults

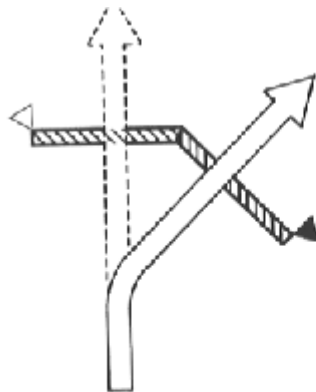

Change of intention by rider

Original intention
Art. 533.2
If no refusal - 0 penalty

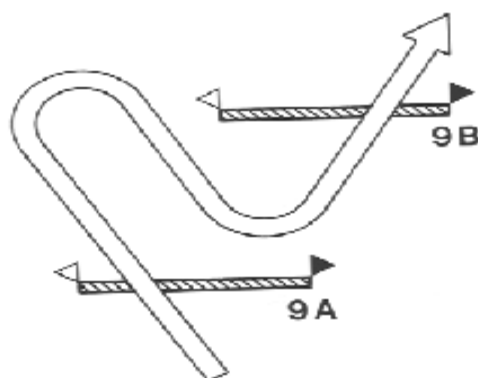

Art. 533.2
If no refusal and no run-out - 0 penalty

2010 RULES FOR EVENTING

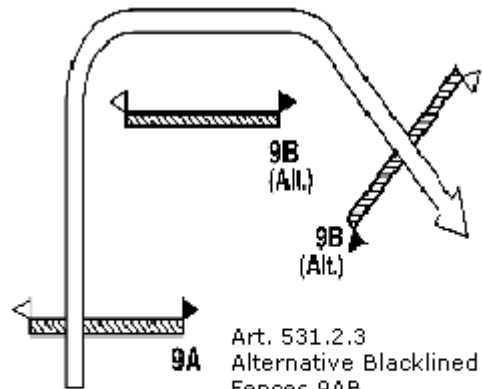

Art. 531.2.3
Alternative Blacklined
Fences 9AB
0 penalty - not presented
at the other alternative

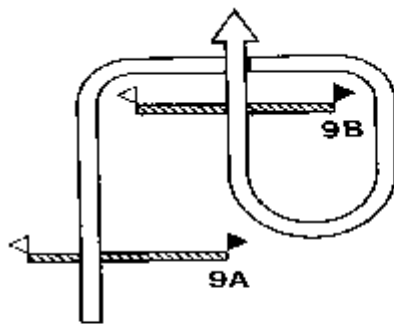

Art. 533.3.1
20 Penalties

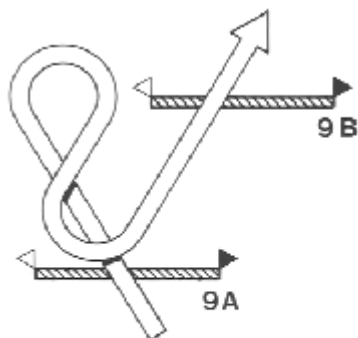

20 penalties - Art. 533.3.1

2010 RULES FOR EVENTING

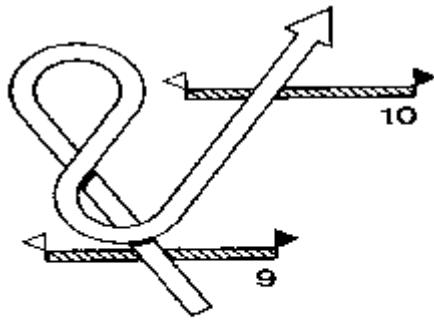

0 penalty - Art. 533.3.3

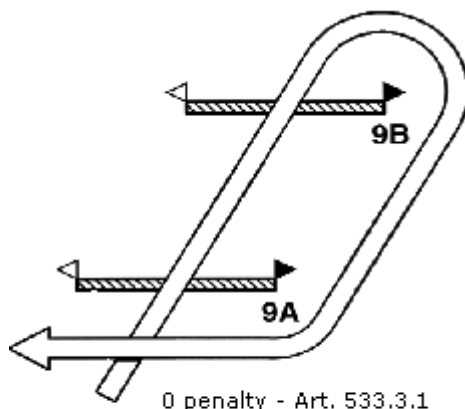

0 penalty - Art. 533.3.1

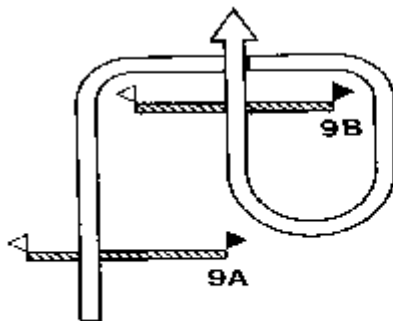

Art. 533.3.1
20 Penalties

2010 RULES FOR EVENTING

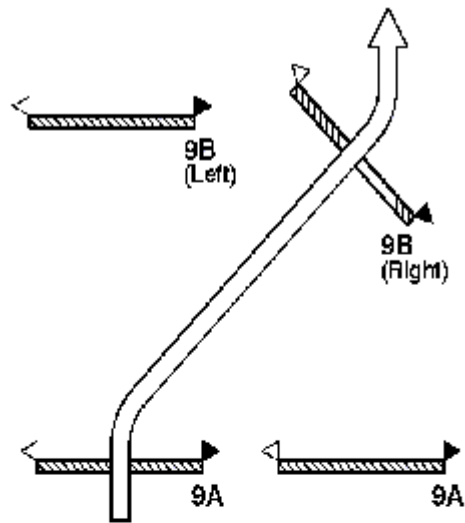

0 penalty - Art. 531.2.3

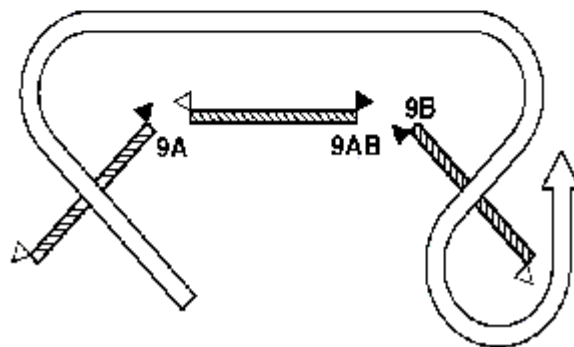

0 penalty - Art. 531.2.3

Missing: Diagram Art. 533.3.1, zero penalties

2010 RULES FOR EVENTING

ANNEX 6 FEI Badges for Honour

Badges of Honour will be awarded to Athletes who complete the competition at Championships/CCI(O)s Four Star Level (4*), according to the following scale:

- A Gold Badge for completing six Championships/CCI(O)s
- A Silver Badge for completing four Championships/CCI(O)s
- A Bronze Badge for completing two Championships/CCI(O)s.

Eventing at the Olympic Games or at the World Championships is equivalent to two CCI(O)s.

ANNEX 7

Athlete Identity – refer to Art 519.1

Recommendations for Medical Services at FEI Competitions

MEDICAL ATTENDANCE AT EVENT: The provision of medical cover must be for the whole duration of the competition and must include the training areas, stables and on-site accommodation. First aid must also be provided for spectators. There should be a physician in the stable area at competitions if feasible. At the least, a physician should have credentials allowing access to the entire facility at all times including the stable area and finish area during competition

CHIEF MEDICAL OFFICER: A Chief Medical Officer, suitably experienced and with local knowledge must be appointed well in advance, to act in liaison with the Organising Committee and the emergency services for the adequate provision of medical resources.

A meeting of medical officers or delegates should be held at the cross country venue to familiarize them with the event plan and services available by the host physicians in case of emergency.

A list of phone numbers of medical officers for each team should be obtained at every competition. For teams with no physician, the physiotherapist, or trainer, or lay person designated as a contact in the event of a medical emergency should give a contact phone number to the host physicians.

Text messaging to the medical officers in the event of the need for medical services is a valuable way to communicate. This can be done to a specific physician, or can be a general notice depending on the issue.

CROSS COUNTRY: At least during the Cross-Country and Jumping Test, full specialist trauma and resuscitation skills, equipment and vehicles must be available on site; the latter should have the capability of rapid deployment to any part of the arena or course in adverse conditions. Radio communication should be made available to alert the emergency services instantly and a telephone line reserved for immediate communication with the designated accident and emergency hospital.

The Cross-Country Test will require several qualified doctors experienced in dealing with trauma, the number depending on the layout of the courses and the accessibility of the site. However, there must be at least one doctor present throughout all the tests.

A Medical Centre should be established on site for the treatment of minor ailments and for the observation and initial treatment of serious injuries or illness. Rapid routes for access and departure must be prepared and safeguarded for the expeditious transfer of the seriously injured to hospital. Depending on the access to the site and the distance to hospital, helicopter evacuation may be required. A suitable area adjacent to the medical centre

2010 RULES FOR EVENTING

should be provided. The provision of a suitably equipped helicopter is in any case recommended.

If an athlete falls at a competition, he should not be allowed to continue without a medical assessment, even if the athlete has no obvious injury. Frustrated athletes who fall and then refuse medical attention create an issue for the host medical service providers. Athletes have the right to refuse treatment, but not the right to compete with injuries that may be undetected.

ANNEX 8

Organising Requirements for Eventing 4 Star Level Events

Four star events are believed to be the pinnacle of the sport representing Eventing on the world stage and as such it is felt that there should be some guidelines for potential OCs to ensure that the image of the sport and the presentation of the event are of the highest possible quality.

The FEI will only recognise a few events at this level and this recognition will be subject to some strict criteria.

1. **BEFORE BEING AWARDED AN EVENT OF FOUR STAR STATUS** the OC must have run, at the venue, a lower level international Eventing competition of at least Three Star level, and demonstrated the ability to stage an event of the highest level.
2. **APPLICATION FROM THE HOST NF** to the FEI to stage a Four Star competition must be accompanied by a proposal including detailed information about the venue (access, facilities, etc) and the suitability of the footing, the OC, the financial viability (including proposed levels of sponsorship income), budget and cash-flow, local accommodation availability, and proposed level of prize money.
3. **THE OC** must have a proven track record of success. A business plan must be presented.
4. **TV STRATEGY:** Details in regard to the OCs TV strategy as well as expressions of interest in regard to TV coverage.
5. **THE VENUE** needs to be approved by an FEI appointed Delegate, who will visit the proposed event at the OC's/NF's expense.
6. **THE NF WILL BE RESPONSIBLE** for supporting the application and overseeing the success of the event, and a representative of the NF must be included in the Board of the OC.
7. **MINIMUM LEVEL OF PRIZE MONEY:** € 100'000 (CHF 156'000 / \$ 123'000).
8. **REQUIREMENT FOR CCTV:** Mandatory for public, Athletes, owners and the Ground Jury and for safety reasons.
9. **COURSE DESIGNER:** must be an International Eventing Course Designer and proposed name must be included in the proposal. The Course Designer in question must support the proposal and guarantee that the venue is suitable for the Four Star.
10. **ALL WEATHER DRESSAGE ARENA:** strong recommendation.
11. **DATES:** dates must fit in to overall Eventing calendar, not clash with any major event and be consistent from year to year in order to allow the other events to position themselves in consequence.
12. **APPLICATION TO BE SENT TO** the FEI by July the year preceding the event applied for.
13. **THE EVENT HAS TO BE APPROVED** by the FEI Eventing Committee who reserve the right to ask for as much information as is considered necessary. The Eventing Committee also reserves all rights to not accept the 4* denomination request of any organiser.
14. **A REVIEW COMMITTEE** composed of Representatives of the Eventing Committee, FEI Delegate and the FEI Secretary General will assess existing Four star events on a yearly basis. Should any event not fulfil requirements it will be possible to re-evaluate the star level.

ANNEX 9

Directives For One & Two Star CCI/CIC with Several Sections for the Same level in Regard to Ground Juries

1. If an OC wishes to organise several sections of competitions at the same level of difficulty at a one or two star CCI/CIC the whole competition can be treated as a single entity as follows:
2. Where there is more than one section of an event, there shall only be one Ground Jury for the event, consisting of a President and one or two members who will be responsible for all decisions common to the various sections. (President and one member at CICs).
3. Additional Judges will be appointed to assist in the judging of the Dressage, if necessary to make up the horse inspection panels and if required, to help judge the Jumping test. These additional judges may be taken from the FEI lists of official, international or candidate judges or may be national judges. At a CCI there must always be three judges judging each section of dressage; at a CIC there must always be two.
4. At a CCI, at least one member of the Ground Jury must officiate at each Horse Inspection. All horses in any section must be inspected by the same Veterinarian and Ground Jury member at all three inspections.
5. There must be only one Technical Delegate to officiate in all sections of an event organised at the same star level.
6. The Ground Jury must consist of members selected by the OC in accordance with the rules for the relevant star level.
7. The procedure by which Athletes are divided between sections must be specified in the schedule.
8. Prize Money should normally be the same for each section and must be specified in the schedule.
9. Athletes with more than one horse should have their horses split between the sections.

ANNEX 10

Consultation with Athletes

1. Appointment of Athlete Representative

Prior to the Athletes' first opportunity to inspect the cross-country course every Organising Committee (OC) of an international event must appoint an Athlete Representative (RR) from among the Athletes taking part in the competition having first obtained that Athlete's consent. This RR has the task of acting as a channel of communication between the Athletes and the officials on any matter directly connected with the event without in any way removing the right of any Athlete to speak to the OC, Technical Delegate (TD), Ground Jury (GJ), or Course Designer (CD). The name of this Athlete must be notified to the Athletes at the briefing if one is held or posted prominently on the event notice board if no briefing takes place.

2. Chairman of Ad Hoc Committee (AHC)

The OC will appoint prior to the start of the competition the Chairman of an Ad Hoc Committee (AHC) – see # 9 below.

3. 1st meeting of Athletes called by the Athlete Representative – 1st HI

At the end of the day on which the First Horse Inspection is held there will be a meeting of all Athletes should they so wish to be called by the RR. The TD and representative of the OC should attend although not the Ground Jury unless specifically requested by the TD, OC or the RR.

4. 2nd meeting of Athletes called by the Athlete Representative after 1st day Dressage

If the event is a "normal" CCI following a 'normal' timetable the RR has the right, if there are any concerns amongst the Athletes, to ask for an Athletes' meeting to take place at the end of the first day of Dressage to discuss major issues concerning the obstacles on the course and/or the distances of the course/phases. This meeting must be attended by the Ground Jury, TD, CD, and a senior representative from the OC. (If there are no issues the RR may advise the TD who will contact the OC and GJ and cancel the meeting).

5. Meeting Minutes

At this meeting any such issues must be recorded in writing (the TD & RR have this responsibility) and the response of the GJ also recorded in writing and signed by the President of the GJ and the RR.

6. Additional Athlete Representative

At this stage the Athletes may appoint a further two people (to join the already appointed RR) as RR's to continue the discussions with the officials and the OC. These additional two people can be anyone the Athletes choose and do not necessarily have to be competing at the competition.

2010 RULES FOR EVENTING

7. Final Athletes Meeting of the Athletes before the Cross Country

A further and final Athletes' meeting, attended as before by all the officials and a representative from the OC, is now required. Ahead of this meeting the written response by the Ground Jury to any written concerns of the Athletes raised the previous evening shall be given to the RR's. At this meeting any final briefing of the Athletes will take place. If the Athletes are still dissatisfied with the decisions of the GJ a vote will be taken. This should be a secret vote and the OC should assist the Athletes in conduct of the meeting. The issue to be voted on is "Do you accept the responses of the Event Officials, or should they be referred to the AHC for final decision?" If a majority of the Athletes actually taking part in the competition (50% plus one) so agree the outstanding issue(s) will be referred immediately to the AHC for a final decision against which there will be no appeal. At this meeting any such issues must be recorded in writing (TD & RR responsibility) and the response of the AHC also recorded in writing and signed by the Chairman of the AHC and the RR.

8. Athletes Briefing

The usual Athletes briefing on routine matters to do with last minute changes due to meteorological conditions, ground etc must still take place on the evening before the cross-country. In case of dispute on such issues, the procedure with the AHC is available for use.

9. Ad-Hoc Committee

The AHC will consist of three people appointed on the first day of the event by the OC in conjunction with the RR – a non-competing current or recent Athlete experienced at the level of the event, a FEI qualified CD or TD, and a third independent person experienced in the sport, e.g. an Organiser. If such people are not available at the event the OC, in consultation with the TD and the President of the GJ, must appoint a committee of similarly experienced people likely to have the confidence of the Athletes and officials alike. Any one of these three people can be appointed as Chairman. The President or a member of the Appeal Jury may be appointed to this committee if suitably qualified.

10. Events with only 1 day Dressage

At a CIC or CCI with only one day of Dressage it will be necessary to modify the above procedure. In these circumstances the above timetable may be compressed and/or certain steps omitted but the most important principles must be retained, i.e.:

Concerns and responses recorded in writing

The opportunity for Athletes to vote if dissatisfied

Final decision by an Ad Hoc, independent Committee, provided a majority of starters so request

Note: It is recommended that the Ad Hoc Committee established above, whether or not it actually meets or has to take a decision, should also act as the committee of investigation reporting to the President of the Ground Jury in the event of a fatal accident to horse or Athlete and as the

2010 RULES FOR EVENTING

investigators required by the Ad hoc Investigation team (see FEI Eventing Memorandum/Guidelines). This recommendation is intended to avoid duplication of effort and of officials.

The article will not apply for Championships, Team events, Young Athletes or Juniors events. The above will not apply for Championships or team events (RR replaced by Chef d'Equipe) or for Young Athletes, Junior of Pony events.

ANNEX 11

Young Rider/Junior Championships - SCHEDULE Information

The Organising Committee should prepare a schedule, which should include the following information:

1. Type of event
2. Description of the competitions
3. Prizes, trophies to be awarded
4. Height, spread of obstacles, distances, times, speeds and jumping efforts for both the Cross-Country and Jumping Tests together with Dressage Test details
5. Type of obstacles
6. List of Officials (Judges, Technical Delegates, Course Designers, Veterinarians, Stewards) etc
7. Programme of competitions
8. Programme of social events
9. Lodging of Chefs d'Equipe and Athletes which may be in hotel or with private families
10. Arrangements for parents, including a list of hotels where parents can book direct and not through the Organising Committee – list of prices
11. Accommodation of grooms – location in vicinity of stables
12. Stabling of horses – details of cost
13. Fodder available for horses – details of cost
14. Local transportation arrangements
15. Arrival and departure dates, outside which no expenses will be paid
16. Other useful information such as passport and visa requirements, climate, type of clothes needed, etc.
17. Several copies of this schedule should be sent to all NFs at least eight weeks before the start of the event and championship.

ANNEX 12

Rules for Eventing Pony Riders

Pony Riders' competitions are an important element in the development of equestrian sport around the world. The objective of this Annex is to define a framework within which Pony Riders can practise the sport of Eventing in a safe and appropriate way. Thus the FEI Rules of Eventing apply with the modifications and clarifications defined in this Annex.

Administrative Rules

ARTICLE P1 – DEFINITION OF PONY RIDER AND PONY, AND PARTICIPATION

Age of Pony Rider

A rider may compete as a Pony competitor from the beginning of the calendar year in which he reaches the age of 12 until the end of the year in which he reaches the age of 16.

Participation

A Pony competitor may compete in competitions for Juniors and/or Young Riders if appropriately qualified without losing his status as a Pony competitor. He may likewise take part in competitions and Championships of more than one category, but only in one age category and in one discipline of such Championships in any one calendar year.

Definition of a Pony

A pony is a small horse whose height at the withers, having been measured on a smooth level surface, does not exceed 148cm without shoes or 149cm with shoes. Nevertheless, to allow for the fact that FEI pony measurement takes place under competition conditions ponies measured at competition must not exceed 150cm without shoes or 151cm with shoes in order to be permitted to compete.

Age of Pony

In all International Events and Championships, Ponies must be at least six years old.

ARTICLE P2 – INTERNATIONAL PONY EVENTS AND QUALIFICATION

Pony events

Events limited to Pony competitors are designated with a 'P' and are of the 1* and 2* level:

- CCIP1* Introductory level
- CCIP2* Level of the European Championship (for competitors and ponies with more experience)

Qualifications

Pony riders and ponies must be certified by their national federation as qualified to compete at the required level.

2010 RULES FOR EVENTING

ARTICLE P3 – PRIZES FOR PONY COMPETITORS

1. Prize money is not allowed at Pony Events.
2. In all Events, one rosette and a prize in kind or souvenir must be awarded for each commenced four competitors with a minimum of five prizes. It is recommended that stable plaques should be awarded to the first four individuals.
3. Organising Committees may provide additional special awards/prizes of a sporting nature at their discretion.

ARTICLE P4 – PONY MEASUREMENT

1. Annex XVIII of the Veterinary Regulations and the General Regulations (Art 139) of the FEI apply.
2. All ponies competing at the CH-EU-P will be measured on site before starting the competition. Random measuring at various CIP may also take place.
3. Where FEI Pony Measurement is to be carried out before the Horse Inspection, the period of an Event shall commence with the first Pony Measurement. Such provision shall prevail over the General Regulations.

Technical Rules

ARTICLE P5 - DRESS

Protective Headgear

Whenever mounted, protective headgear secured by a 3-point retention harness is compulsory for all Pony competitors. As a safety measure, long hair must be tucked under the headgear or retained in a hairnet.

Spurs

For Pony competitors, the shank must end in a smoothly rounded ball. Rowels are not permitted. Any mark on the pony resulting from inappropriate use of the spurs may lead to sanctions.

Dressage Test

Dark coat or club uniform coat. White or fawn breeches or jodhpurs, white shirt with white or light-coloured tie or hunting stock. Neither top hat nor bowler is allowed. Gloves must be worn. Boots as defined in Article 521 4. Spurs are optional.

Cross-country Test

Jodhpurs are allowed with appropriate footwear.

Jumping Test

Dark coat or club uniform coat. White or fawn breeches or jodhpurs, white shirt with white or light-coloured tie or hunting stock. Neither top hat nor bowler is allowed. Gloves must be worn. Boots as defined in Article 521.4. Spurs are optional.

ARTICLE P6 - SADDLERY

Exercise Areas – Article 522.1 applies except that hackamore, curb and double bridle are not allowed.

Dressage Test – Article 522.2 applies except that curb and double bridle are not allowed (only snaffle bits).

2010 RULES FOR EVENTING

Cross-country and Jumping Tests - Article 522.3 applies except that curb, double bridle, hackamores and bit less bridle are not allowed.

ARTICLE P7 – DRESSAGE TEST

Refer to Annex 2 modified.

ARTICLE P8 – CROSS-COUNTRY TEST

The same rules and regulations apply for one star as for two star Pony events. However, the course should be designed keeping the purpose of the one star event in mind, which it is to introduce ponies and riders to their first one star international competition. In principle, obstacles must be more inviting than the obstacles for two star events, with an acceptable number of alternatives.

Pony Cross Country	Two Star (2*)	One Star (1*)	
Heights			
Fixed	1.05 m	1.05 m	
Brush	1.25 m	1.25 m	
Max Spreads			
Highest Point	1.25 m	1.25 m	
Base	2.10 m	2.10 m	
Without height	2.80 m	2.80 m	
Max Drop	1.45 m	1.45 m	
Pony Cross-Country	Pony Championships	Two Star (2*)	One Star (1*)
Speed	520 mpm	450 - 520 mpm	450 -520 mpm
Time	7 -8 min	6-8 min	6-8 min
Distance	3640-4160m	2700 - 4160m	2700 - 4160m
Jump. Efforts	Max 30	Max 30	Max 30

Types of Obstacles

1. Bull finches are not allowed.
2. Bounce fences (combination of upright obstacles with no stride) are allowed but must not be into water and must be of an appropriate distance, and degree of difficulty, for ponies and pony riders.
3. The drop on the landing side of an obstacle, or of those obstacles that are jumped as a ski jump, may never exceed 1.45m. The number of such obstacles is limited to two. The number of drop fences less than 1.45m is left to the discretion of the Technical Delegate.

ARTICLE P9 – JUMPING TEST

The same rules apply for both one and two star events.

2010 RULES FOR EVENTING

The course should be 400 to 500m with maximum 11 obstacles and 13 jumping efforts, obstacles not exceeding 1.10m in height and maximum 1.35m in spread. There must be at least one double. Speed: 350m per minute.

Jumping CCIP 1*/2*	Pony One Star (1*)	Pony Two Star (2*)
OBSTACLES		
Heights:	1.10 m	1.10m
Overall Spreads		
Highest point	1.25m	1.25m
Base or Triple bar	1.80m	1.80m
Distance	350-450 m	400-500m
Speed	350m/min	350m/min
NB Obst/ Max Efforts	10-11 / 13	10-11 / 14

ARTICLE P10 - OFFICIALS

Duties of Technical Delegates

In addition to the above responsibilities, the Technical Delegate at Championships for Ponies and at International Events shall have the responsibility and the authority to check that all facilities are adequate, that the behaviour of participants is correct and that social and educational functions are conducted with the utmost care, always bearing in mind the welfare of the participants and the development of the best spirit of sportsmanship and fair play.

Officials

Officials are to be appointed according to the Table below. Organising Committees are strongly advised to include officials who have experience of Pony events.

2010 RULES FOR EVENTING

	CH-EU-P	CCIOP2*	CCIP2*	CCIP1*
Ground Jury	3 members	3 members	2 or 3 members	2 or 3 members
	Appointed by FEI, from the FEI	All must be chosen from FEI	All must be chosen from FEI	1 GJ member from the FEI

	"O" or "I" lists	"O" or "I" lists	FEI lists	lists
	At least 2 Members of the Ground Jury must be foreign. President, at least, must have experience judging Pony events	At least 2 Members of the Ground Jury must be foreign. At least 1 GJ member must have experience judging Pony events	One Foreign Member of the Ground Jury or a Foreign TD is compulsory	Can be National Judges if the TD is chosen from the FEI lists
Appeal Committee	1 member with experience of Pony events		N/A	
Technical Delegate	Appointed by the FEI from "I" list	Must be chosen from the FEI "I" list of Technical Delegates		One member of the GJ or the TD must be chosen from FEI lists. The TD may be National if a member of the GJ or the CD is on the FEI lists
Course Designer	Must be chosen from the FEI "I" list of CDs			May be from the FEI lists or be a National CD as long as a member of the GJ or the TD is on the FEI lists

ARTICLE P11 - CONTINENTAL CHAMPIONSHIPS

The Continental Championship will be organised each year and, as far as possible, during the long school holidays.

2010 RULES FOR EVENTING

Jumping, Dressage and Eventing Championships should be, as far as possible, organised within the same Event to save travel costs. Organising should alternate among the nations of the Continent, giving the Pony competitors the possibility to visit as many foreign countries as possible.

Outside Europe, a Continental Championship may be held with any number of regional teams from at least two countries including the host nation. The NF's of the nations concerned will determine the basis of the regional teams.

NF's from outside the Continent may be invited if authorised by the Secretary General of the FEI, but no rider may take part in two Championships in the same discipline within one calendar year. Riders from outside the Continent are eligible for prizes but not for medals or title classification.

Teams

Each NF may enter one team of not more than ~~six~~ **four** competitors and ~~six~~ **four** ponies from which four may start in the Team Championship. Teams of three are allowed. An NF which cannot send a Team may enter one or two individual competitors with one pony each.

Individuals in addition to teams: two individuals per nation (including the host nation) are authorised to take part in the Championship in addition to each team.

For each team, the Organising Committee must extend its invitation to a Chef d'Equipe and a Veterinarian who will be given the same privileges as the competitors.

Grooms

NFs are entitled to send one groom for each two ponies with a maximum of three grooms per team.

Competitions

Championships will be run as CCIP2* competitions.

Officials for Championships

The President and members of the Ground Jury, the TD and the Foreign Veterinary Delegate will be appointed by the FEI who will approve all other appointments. Other officials will be appointed by the Organising Committee/NF based on the criteria set out in the Table below.

The Organising Committees are strongly advised to include officials who have experience of Pony events.

Expenses

NFs are responsible for the travelling expenses of their Chefs d'Equipe, competitors, grooms and ponies to and from the location of these Championships.

Reasonable entry fees may be charged and must be approved by the FEI.

The Organising Committee must make appropriate provision for on site stabling and for the grooms to stay in the immediate vicinity of the stables.

If accommodation is not offered free to the competitors, then suitable accommodation should be defined and listed in the Schedule.

Prizes and Souvenirs

At Championships only prizes in kind can be awarded; prize-money is not allowed. The following minimum number of awards must be presented:

2010 RULES FOR EVENTING

In the Team Championship, FEI medals will be distributed. In addition, prizes in kind, plaques and rosettes for each of the competitors in the teams taking the first four places.

In the Individual Championship, FEI medals will be distributed. In addition prizes in kind, plaques and rosettes at a rate of one prize for each commenced four competitors with a minimum of five prizes. Organising Committees may provide additional special awards/prizes of a sporting nature at their discretion.

All Chefs d'Equipe and competitors shall be presented with a souvenir or a plaque by the Organising Committee. At Championships, the prize giving ceremonies must be given particular importance and held in the arena with the prize winners properly dressed and mounted on their ponies.

NEW ANNEX 13

1. FEI Stable Security

Requirements for Continental/Regional Games, FEI Eventing Championships, World Cup Finals, World Cup Qualifiers, CCI4*/3* events, please refer to the FEI Veterinary Regulations Art. 1005 and Annex.

2. Reduced Stable Security

The following measures for CCI2*/1*; CIC3*/2*/1* events apply. Measures can be reviewed on an annual basis according to necessity and experience.

2.1 The welfare of horses must not be compromised in any way.

2.2 Stabling must be provided, if possible, on the showground site for all competing horses. Veterinary supervision and stewarding of horses applies to horses not stabled in the event facilities (Veterinary Regulations) as it does to those stabled at the event.

2.3 Safe stabling and equal and fair treatment for all competitors is required to be ensured for all forms of stabling proposed.

2.4 For all CCI4/3* and CIC3* all competing horses must use the official event stables on showground site.

2.5 For CIC3* held on 1 day, stabling on site may not apply.